

INNOVATION
MADE IN GERMANY

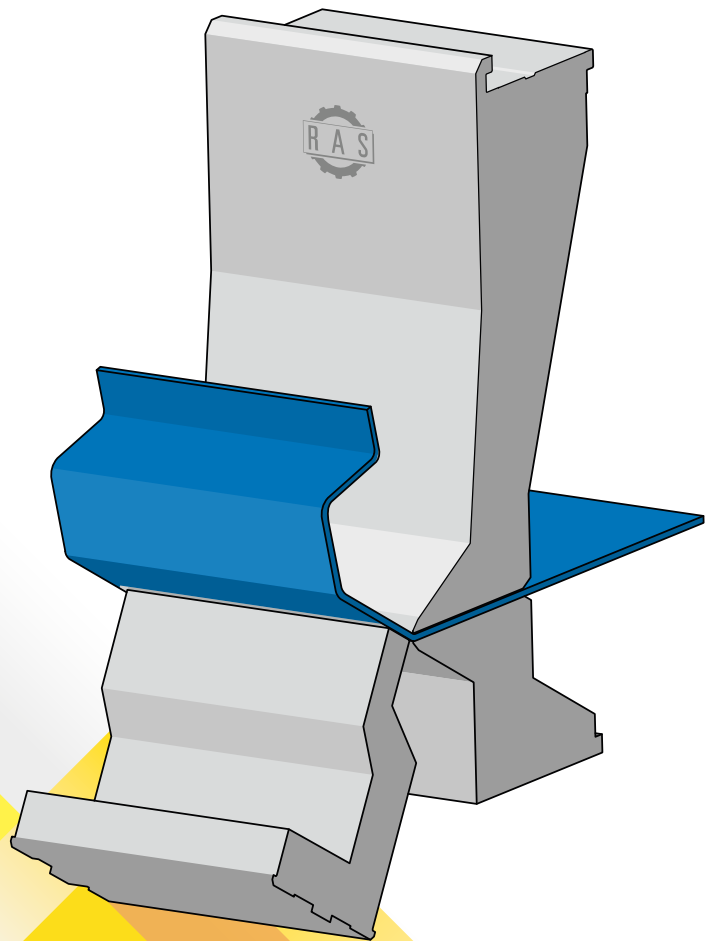

RAS REINHARDT MASCHINENBAU GMBH

Production Program

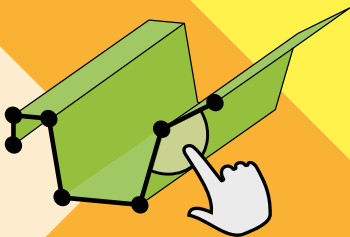
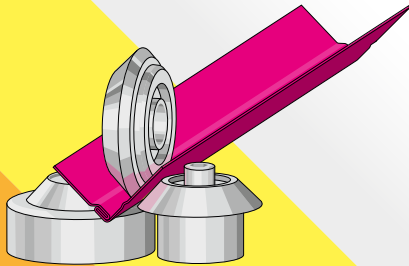
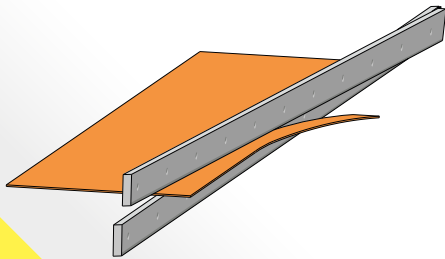

WWW.RAS-ONLINE.DE

BENDING CENTERS

UpDownCenter-2



The RAS UpDownCenter-2 bends sheets up to 4 mm thick, up to 4060 mm bending length and a max. tool height of up to 600 mm.

The one-click part programming software, the automatic tool changer, the UpDownTools in the folding beam and an extremely flexible suction cup plate positioning system adds maximum efficiency.

Folding technology innovations that result in precision parts



Upper beam tools as tall as 600 mm

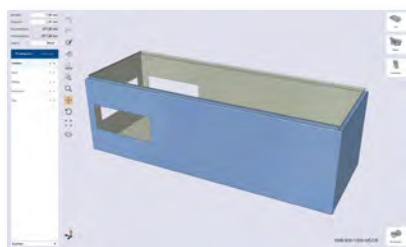

STEP file import of a part

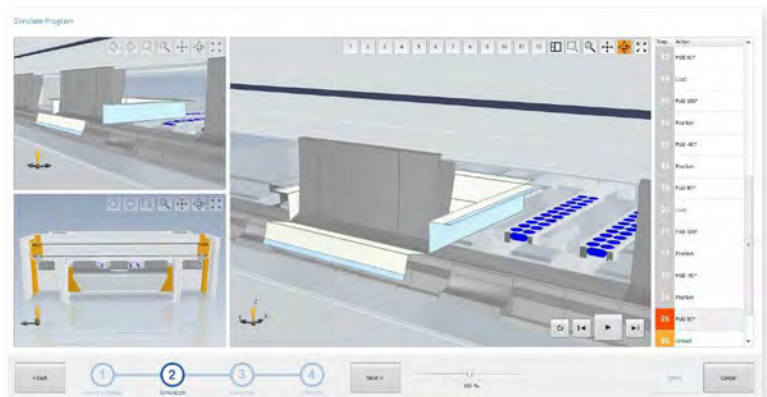

The 3D simulation shows the folding sequence and possible collisions. New products can be evaluated during the design process.

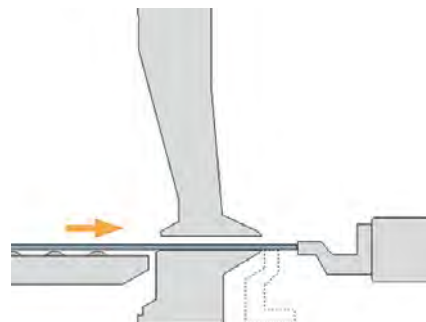

The automatic tool changer for quick tool set-ups extends production times.

Extended flexibility, as the folding beam can be used as a gauging stop.

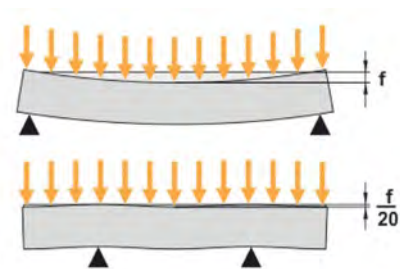

Maximum bending accuracy due to the patented beam-in-beam folding beam design.

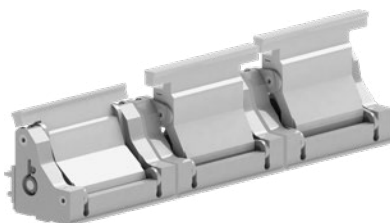

Folded UpDownTools for sectional bending.

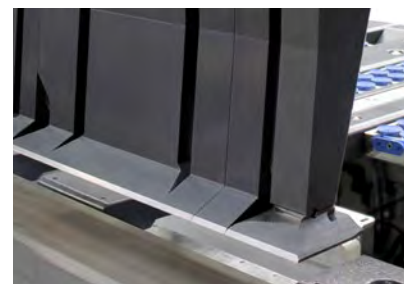

Only one set of upper cheek tools with heel to squeeze envelopes for great design flexibility. Bending of high four-sided parts.



Upper beam tools for boxes up to 600 mm tall.



Suction cups for small parts allow safe positioning of small workpieces.

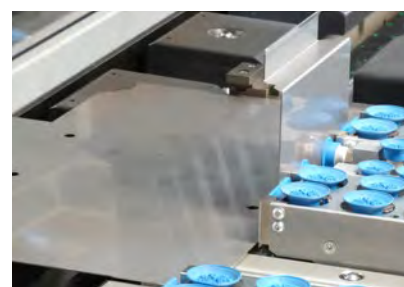

High flexibility in handling due to front suction cups and small part suction cups.



UpDownCenter-2

RAS 78.33-2/30-2

RAS 78.43-2/40-2

BENDING LENGTH MAX.	3200 mm	4060 mm
SHEET THICKNESS MAX.	4.0 mm	3.0 mm
BOX HEIGHT MAX.	600 mm	600 mm

RAS REINHARDT MASCHINENBAU

The company

RAS is proud to manufacture and distribute high-quality premium sheet metal fabrication products. Our expertise runs the gamut of developing groundbreaking solutions that help our customers achieve their goals.

At RAS, we firmly believe in the importance of first-class advice and expertise. Our mission statement is to treat each customer as if they were the only one, because we value each customer's individual needs and requirements.

What sets us apart at RAS is our commitment to setting the highest standards for our own business. We demand continuous excellence from ourselves and strive to exceed our customers' expectations. With over 200 attractive and safe workplaces, we offer not only first-class products, but also a supportive working environment for our employees.

Our focus is on identifying and developing our strengths. At RAS, we understand that continuous improvement is the key to success. As a family business, we build on mutual trust, both within our company and in our relationship with customers and partners. We focus on maximum vertical integration and consistently high quality in all our products—in line with the "Made in Germany" label.



INNOVATION



MADE IN GERMANY

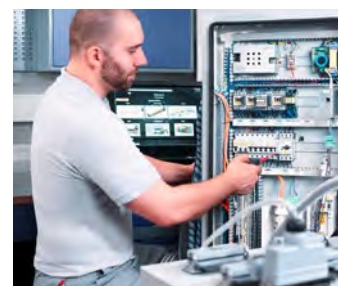
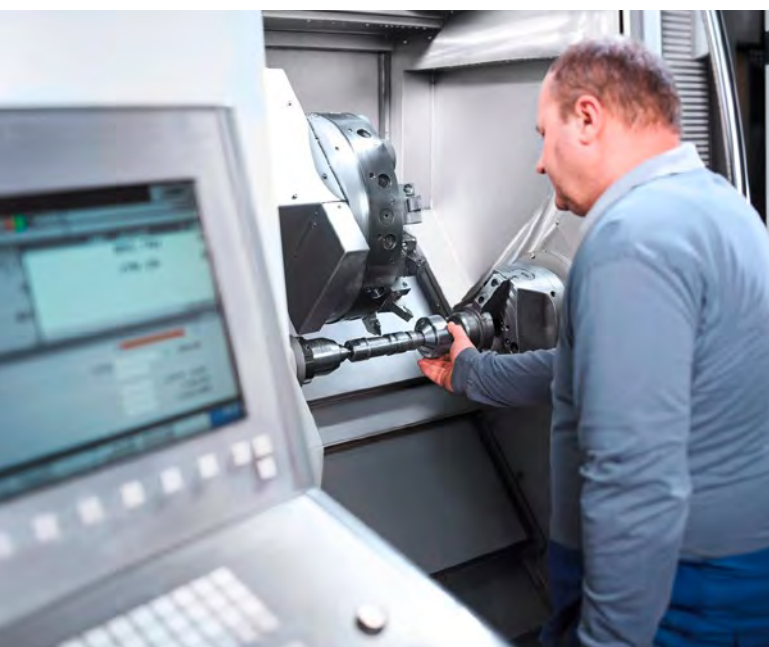
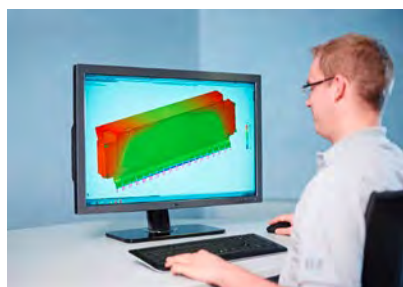

Mutual trust, maximum vertical integration and consistently high quality





INNOVATION
MADE IN GERMANY

Bending

Cutting

Forming

Software

RAS Reinhardt Maschinenbau GmbH
Richard-Wagner-Straße 4 – 10
71065 Sindelfingen

Fon: + 49-7031-863-0
info@ras-online.de

WWW.RAS-ONLINE.DE