

INNOVATION
MADE IN GERMANY

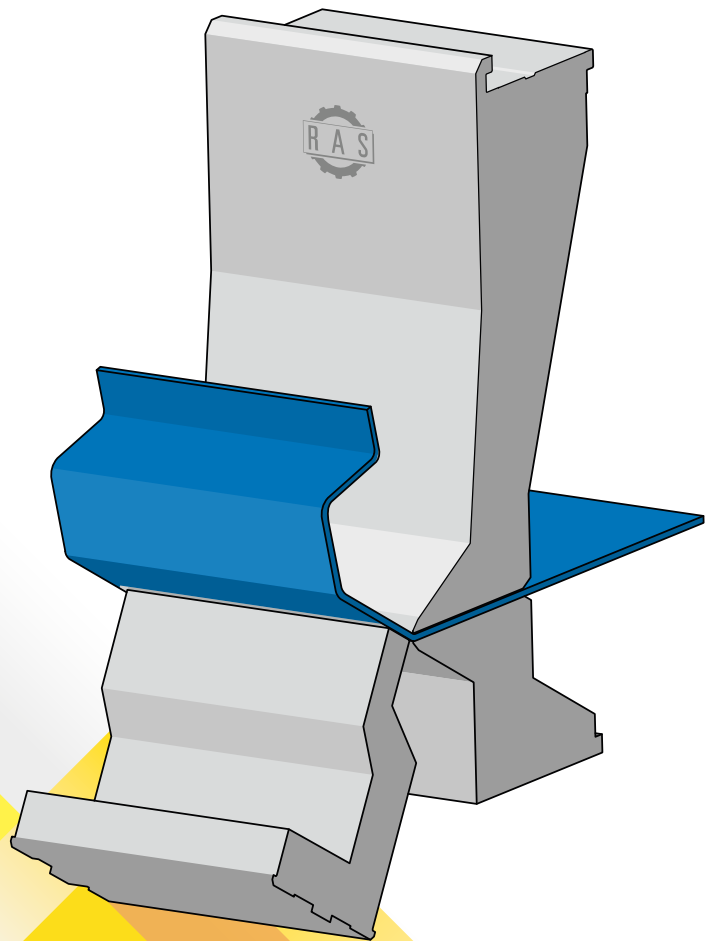

RAS REINHARDT MASCHINENBAU GMBH

Production Program

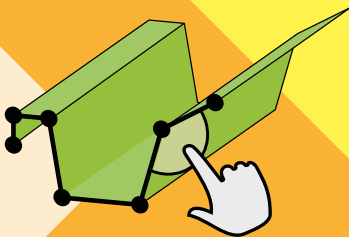
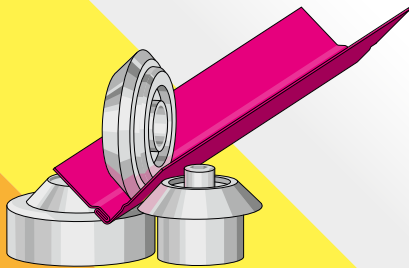
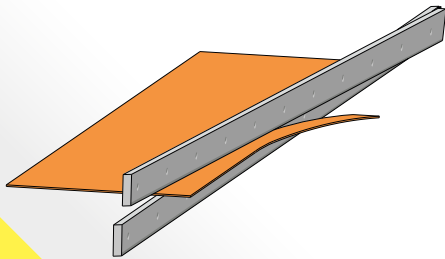

WWW.RAS-ONLINE.DE

Bending

FOLDING MACHINES

TURBO2plus



OpenEditor table input

CONIC BENDING opens up completely new possibilities for the TURBO2plus for bending roof and facade profiles, as well as advertising signs or enclosures!

The Bendex software automatically programs the parts, evaluates alternative bending strategies, and shows the bending sequence on the monitor in 3D.

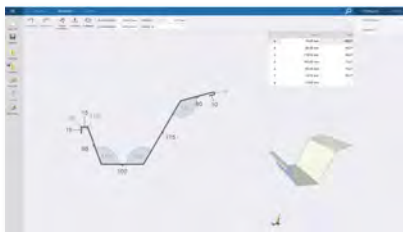

Automatic programming of the bending sequence in the graphics software.

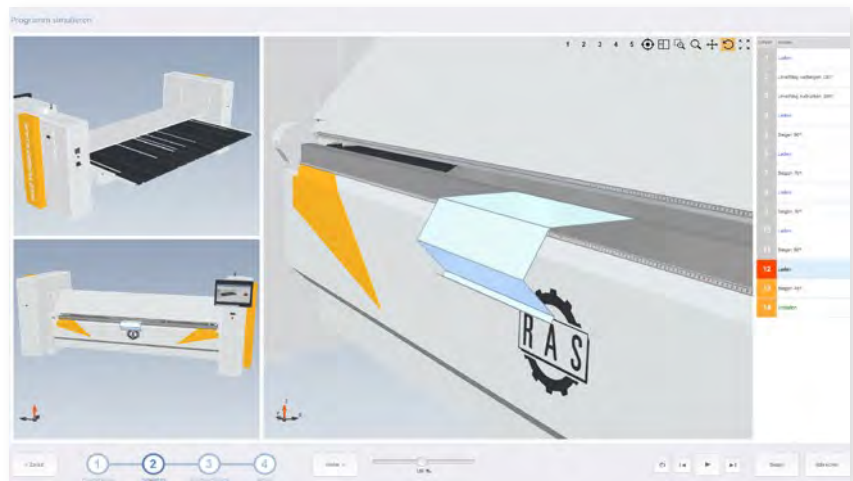

The 3D simulation visualizes the bending sequence and shows when the part needs to be flipped or rotated.



Conic bending with the TURBO2plus

Tools with radius for bending aluminum.

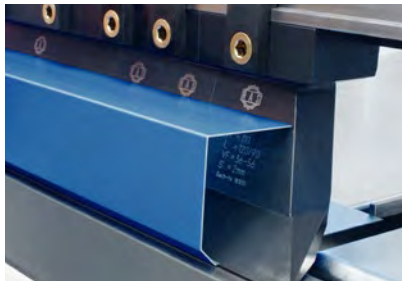
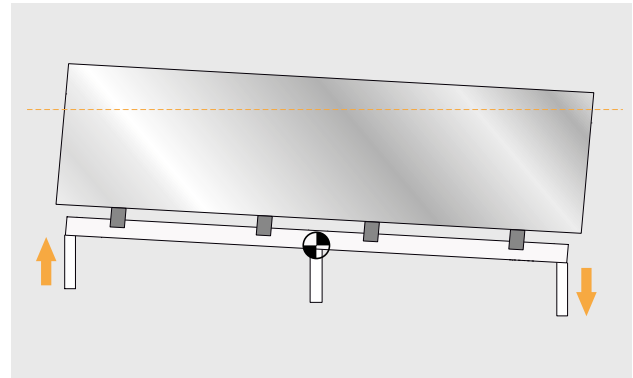

Segmented upper beam tools with front free space



Tools with quick clamping system



Alternative: XL folding beam with extra free space.



A laser automatically recognizes the exact tool height.



Setting the CrownTool (especially for step bending of radii).

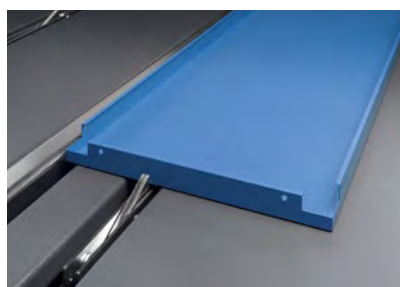

Long and slim parts aligned with the squaring arm.

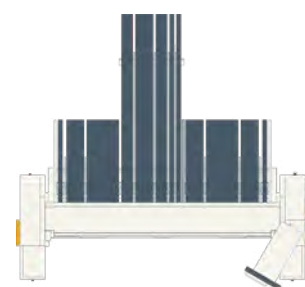

Center Gauging system extended in the middle (T-shape) for best bending results on large panels.



	TURBO2plus	RAS 62.25-2	RAS 62.30-2	RAS 62.40-2
BENDING LENGTH MAX.		2540 mm	3200 mm	4060 mm
SHEET THICKNESS MAX.		2.5 mm	2.0 mm	1.5 mm

RAS REINHARDT MASCHINENBAU

The company

RAS is proud to manufacture and distribute high-quality premium sheet metal fabrication products. Our expertise runs the gamut of developing groundbreaking solutions that help our customers achieve their goals.

At RAS, we firmly believe in the importance of first-class advice and expertise. Our mission statement is to treat each customer as if they were the only one, because we value each customer's individual needs and requirements.

What sets us apart at RAS is our commitment to setting the highest standards for our own business. We demand continuous excellence from ourselves and strive to exceed our customers' expectations. With over 200 attractive and safe workplaces, we offer not only first-class products, but also a supportive working environment for our employees.

Our focus is on identifying and developing our strengths. At RAS, we understand that continuous improvement is the key to success. As a family business, we build on mutual trust, both within our company and in our relationship with customers and partners. We focus on maximum vertical integration and consistently high quality in all our products—in line with the "Made in Germany" label.



INNOVATION



MADE IN GERMANY

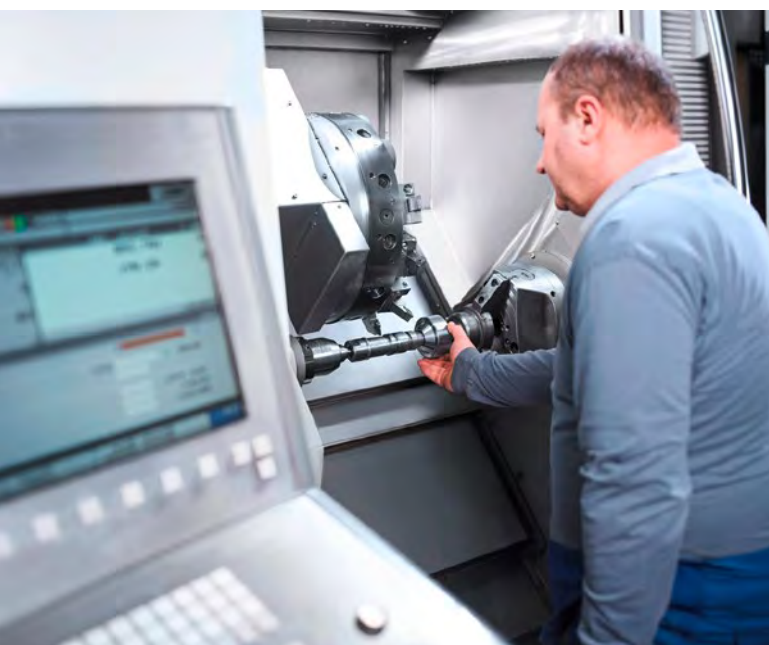
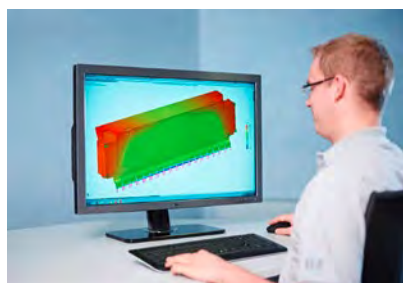

Mutual trust, maximum vertical integration and consistently high quality





INNOVATION
MADE IN GERMANY

Bending

Cutting

Forming

Software

RAS Reinhardt Maschinenbau GmbH
Richard-Wagner-Straße 4 – 10
71065 Sindelfingen

Fon: + 49-7031-863-0
info@ras-online.de

WWW.RAS-ONLINE.DE