

INNOVATION
MADE IN GERMANY

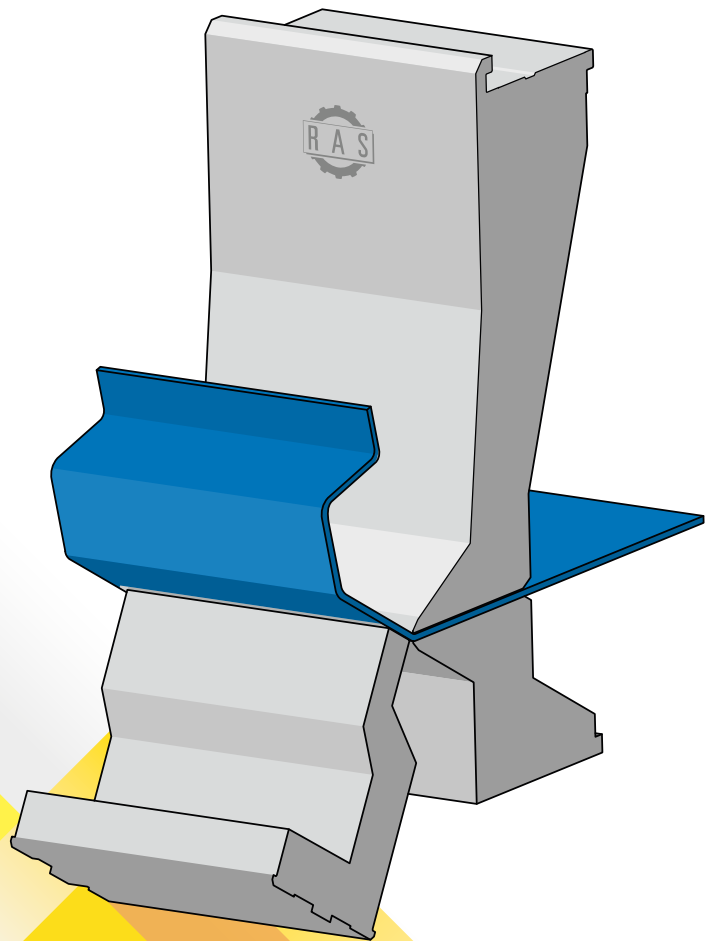

RAS REINHARDT MASCHINENBAU GMBH

Production Program

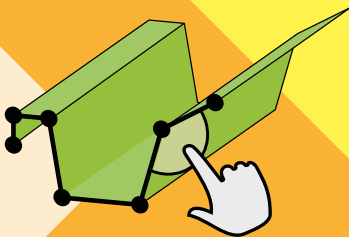
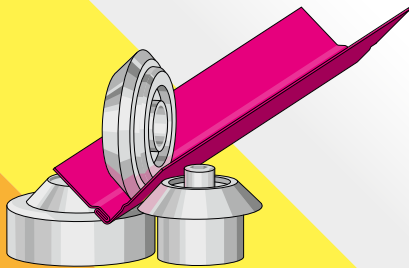
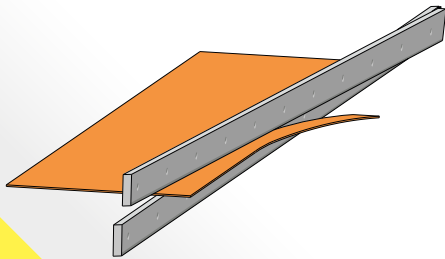

WWW.RAS-ONLINE.DE

Cutting

SWING BEAM SHEARS

PRIMEcut

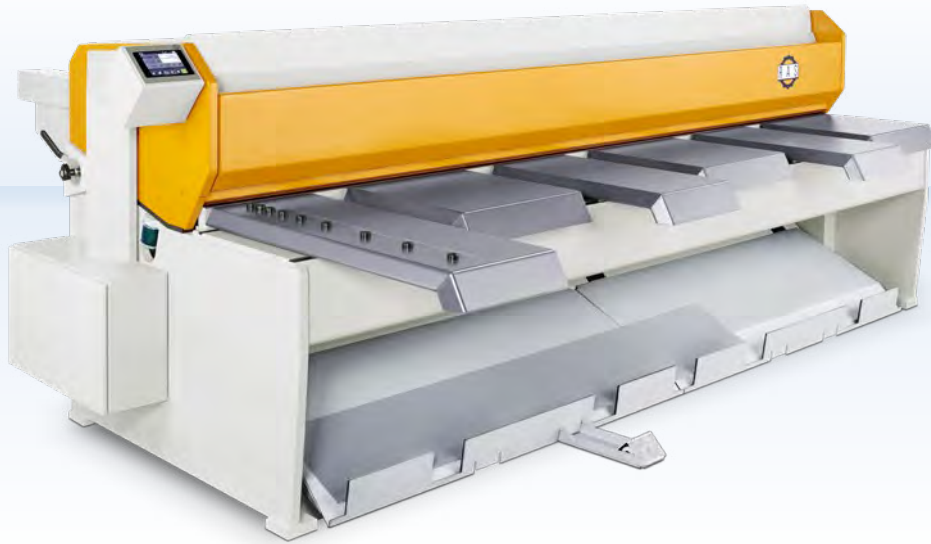

RAS has added a TouchScreen control to the PRIMEcut swing beam shear, thus giving optimum clearness on the monitor. With its 3 mm capacity and 3100 mm cutting length the RAS PRIMEcut combines all characteristics of a high performance, premium shear.

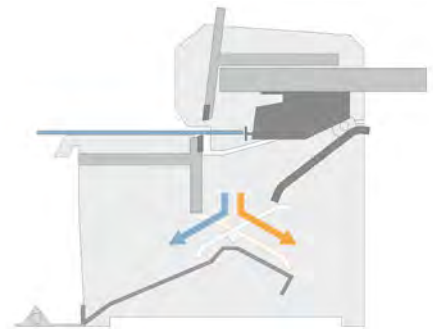

Sorting the cut pieces to the front (up to 750 mm) and to the rear (up to 250 mm).

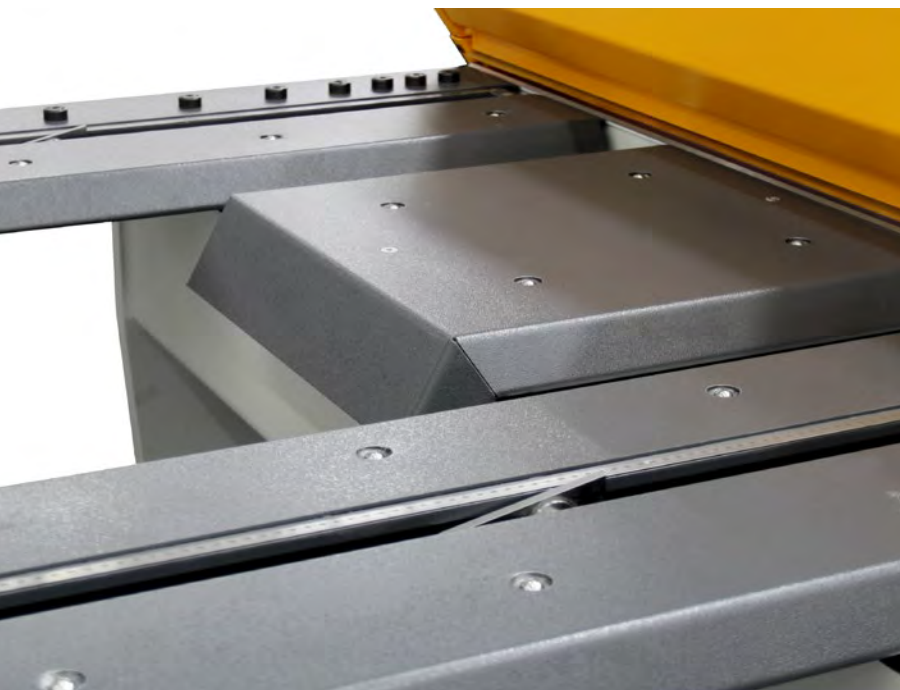



The very easy-to-use TouchScreen control positions the stop to the programmed dimension and processes the desired number of pieces.



Lever for the cutting gap adjustment on the PRIMEcut.

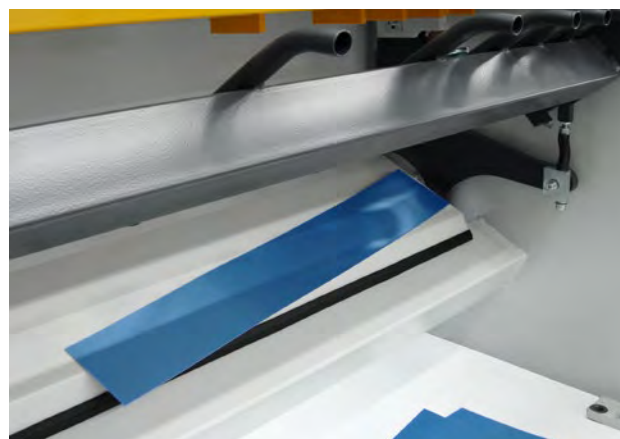

Parts chute for cut piece delivery to the rear.



PRIMEcut

RAS 53.30

CUTTING LENGTH MAX.	3100 mm
SHEET THICKNESS MAX.	3.0 mm
GAUGING DEPTH	5-750 mm

RAS REINHARDT MASCHINENBAU

The company

RAS is proud to manufacture and distribute high-quality premium sheet metal fabrication products. Our expertise runs the gamut of developing groundbreaking solutions that help our customers achieve their goals.

At RAS, we firmly believe in the importance of first-class advice and expertise. Our mission statement is to treat each customer as if they were the only one, because we value each customer's individual needs and requirements.

What sets us apart at RAS is our commitment to setting the highest standards for our own business. We demand continuous excellence from ourselves and strive to exceed our customers' expectations. With over 200 attractive and safe workplaces, we offer not only first-class products, but also a supportive working environment for our employees.

Our focus is on identifying and developing our strengths. At RAS, we understand that continuous improvement is the key to success. As a family business, we build on mutual trust, both within our company and in our relationship with customers and partners. We focus on maximum vertical integration and consistently high quality in all our products—in line with the "Made in Germany" label.

INNOVATION



MADE IN GERMANY



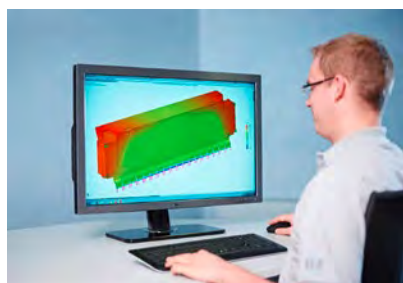

Mutual trust, maximum vertical integration and consistently high quality





INNOVATION
MADE IN GERMANY

Bending

Cutting

Forming

Software

RAS Reinhardt Maschinenbau GmbH
Richard-Wagner-Straße 4 –10
71065 Sindelfingen

Fon: + 49-7031-863-0
info@ras-online.de

WWW.RAS-ONLINE.DE