

Production Program

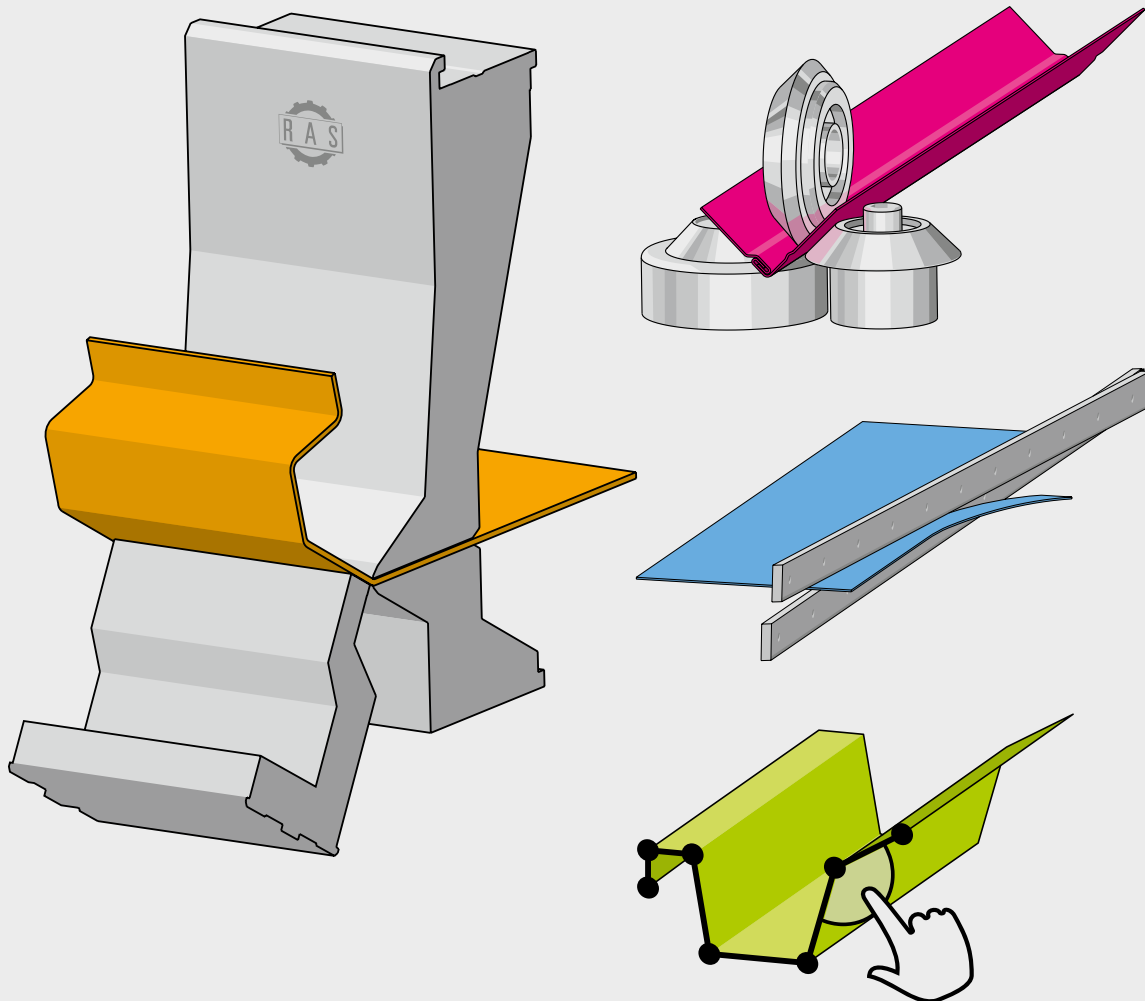

CUTTING

BENDING

FORMING

SOFTWARE

MiniBendCenter

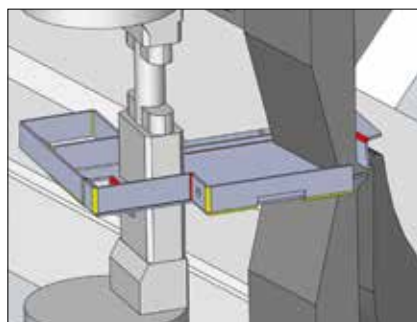
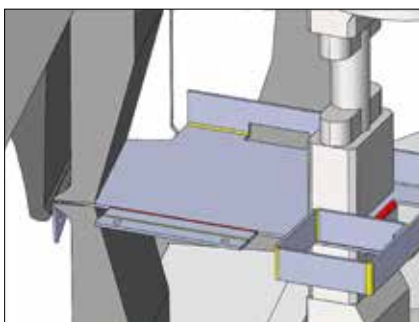

Simple to use Office software starts from a STEP file of the part with 3D visualization of the bending processes.

Fully automatic bending of even complex parts up to 3 mm steel sheet.



The RAS MiniBendCenter is the world's only folding center for small parts. The blanks are automatically loaded, aligned and squared. Tool setup is automatic.



The automatic tool setup allows for quick change-over between parts and the production of small batch sizes.



Robotic loading offers maximum flexibility. Blanks can be loaded from a bulk material box or from stacks.



Measuring the parts by a laser scanner.



Several bending stations can be setup along the length of the machine. Complex parts can be completed in a single run.



Highest levels of precision and repeatability



Dedicated unloading of the finished parts depending on floor space conditions, material flow, and sensitivity of the parts.



Unloading of finished parts into bulk material containers.

Technical data	Sheet thickness max.	Blank size min.	Blank size max.
MiniBendCenter RAS 79.05	3.0 mm	50 x 40 mm	600 x 600 mm

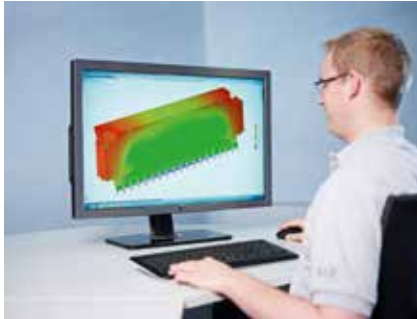

Design



Sawing



Plasma cutting



Milling



Turning



Grinding



Welding



Powder coating



Assembly



Electrical assembly



Quality inspection



RAS - Regional production for global sustainability



Headquarters in Sindelfingen. In the foreground „Steel object“.



Effringen - factory and artwork



RAS Systems LLC in Georgia, USA



Founder Wilhelm Reinhardt



Managing Directors Rainer Stahl, Matthias Huber und Willy Stahl

All sheet thickness refer to 400 N/mm²
tensile strength. Subject to changes.
Pictures may show options.