

INNOVATION MADE IN GERMANY

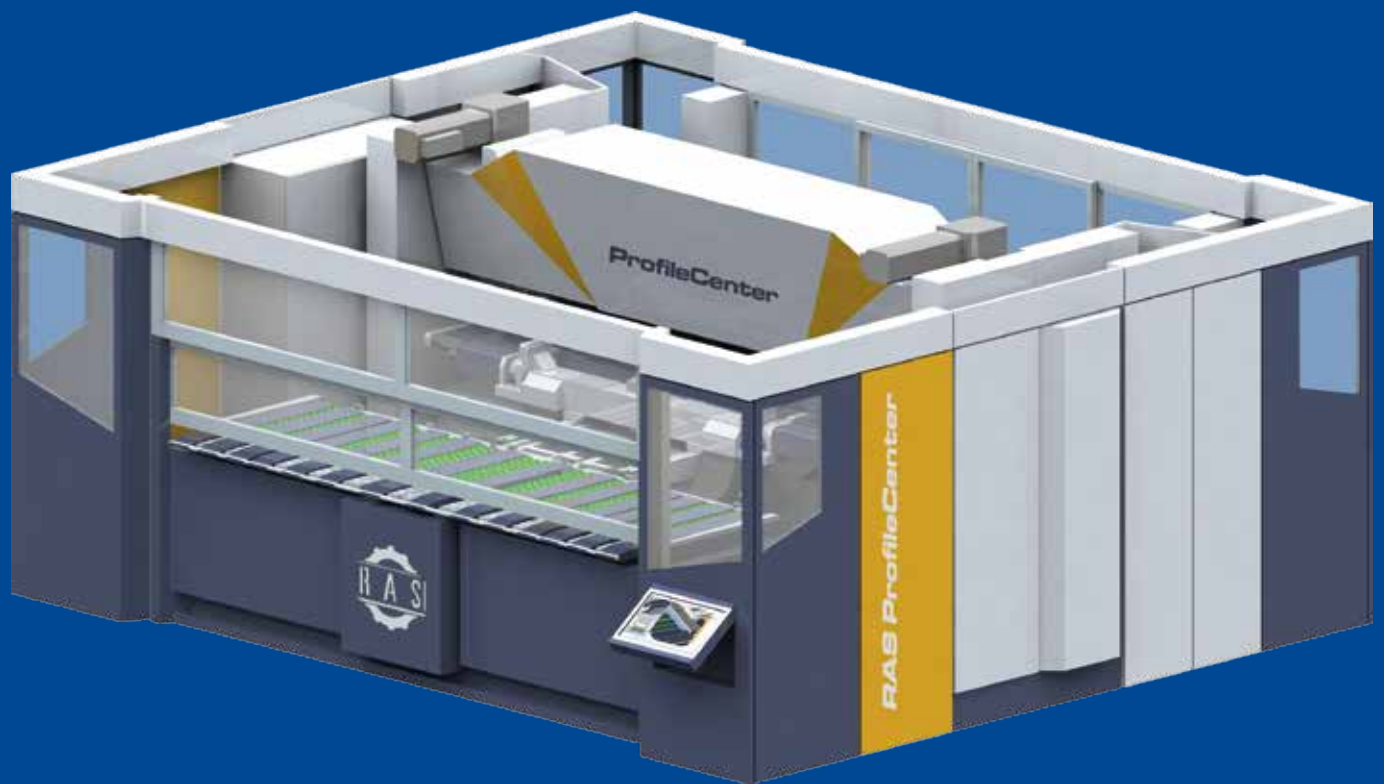

# ProfileCenter



CUTTING

BENDING

FORMING

# ProfileCenter

## Precision bending in batch size 1

The servo-electric **RAS ProfileCenter** automatically bends profiles such as door frames, elevator components or cable ducts in batch sizes as low as 1. The unique FlexGripper Positioning System moves, rotates and flips the blank automatically during the folding process. Before the folding sequence starts, the blank will be squared once. During the subsequent folding cycle, the machine operates without the need for additional positioning stops. This results in fast bending processes, short cycle times and low part costs.

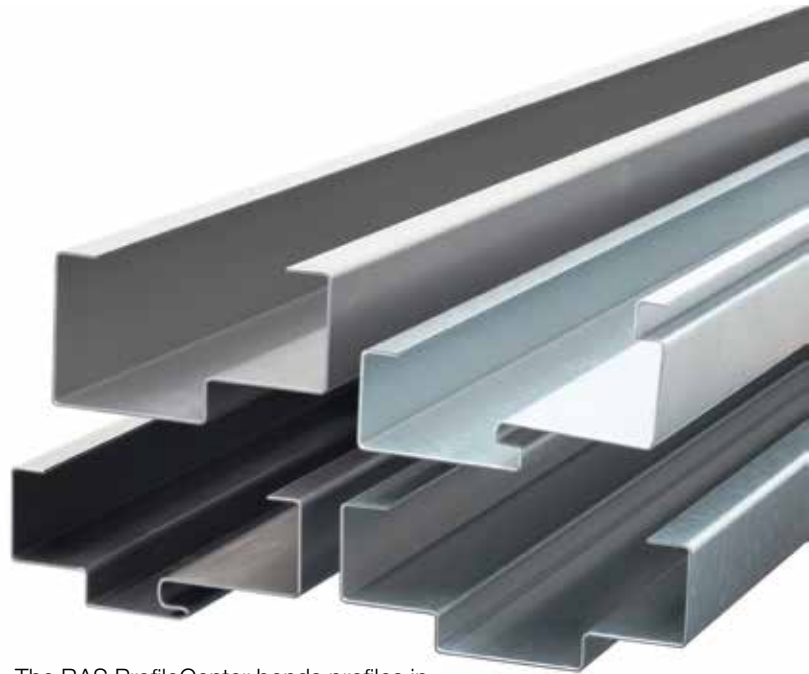

The RAS ProfileCenter bends profiles in batch sizes of 1 - flexibly and precisely!



Folding technology is based around the moving folding beam. The ProfileCenter uses a tall and slim folding beam tool, designed exactly for bending complicated profiles.



The tools of the upper and lower clamping beam are designed with unique geometries and have huge free space areas. Through finite element optimization, they are designed for 2 mm mild steel applications.

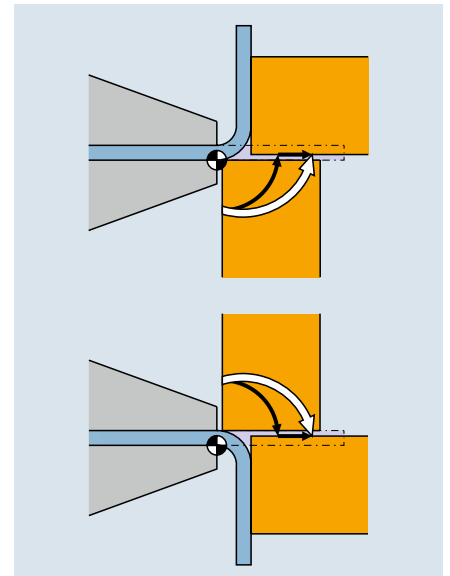

The folding technology uses the approved and patented RAS 3D bending process. The folding beam tool rolls away with the material. This ensures scratch-free bending, which is especially important for stainless steel and visible profiles.

## Fascinating One-Click Programming

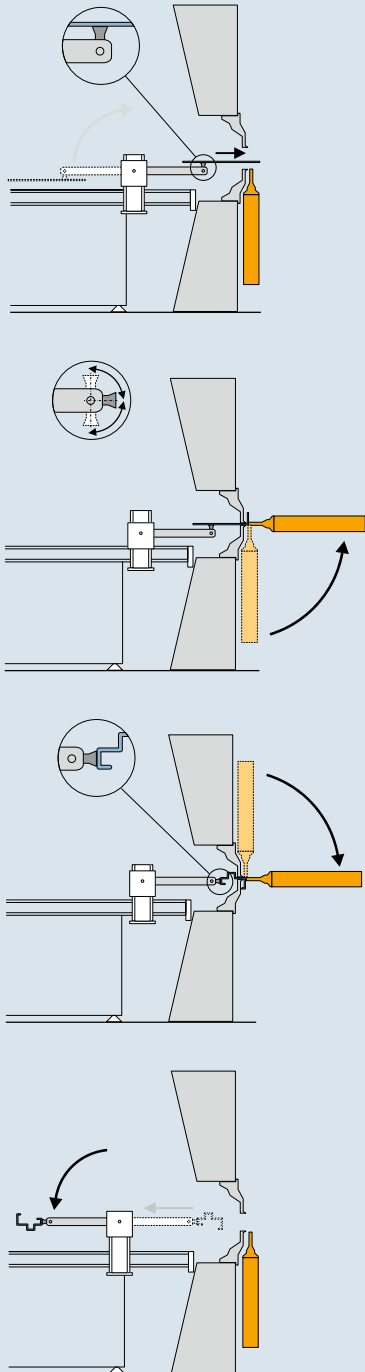

The suction bar can grab the blank from below, from above or from behind and can automatically change its access position during the folding sequence.

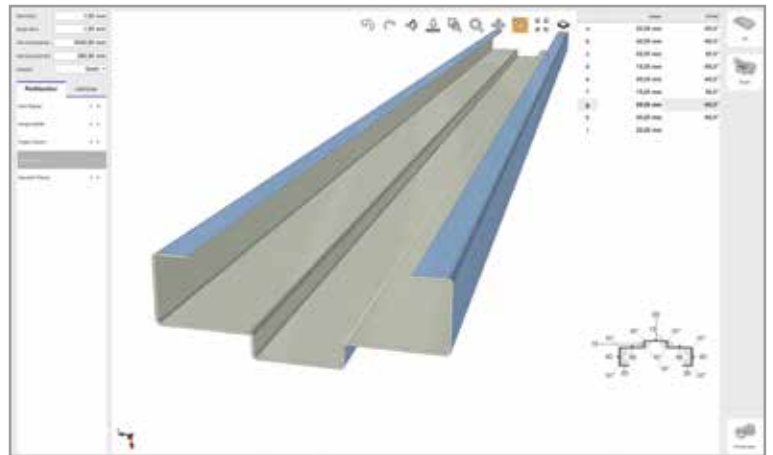

The operator just pulls a STEP file (alternatively: DXF, GEO) of the profile by drag-and-drop into the RAS software. With a single mouse click, the part is automatically programmed!

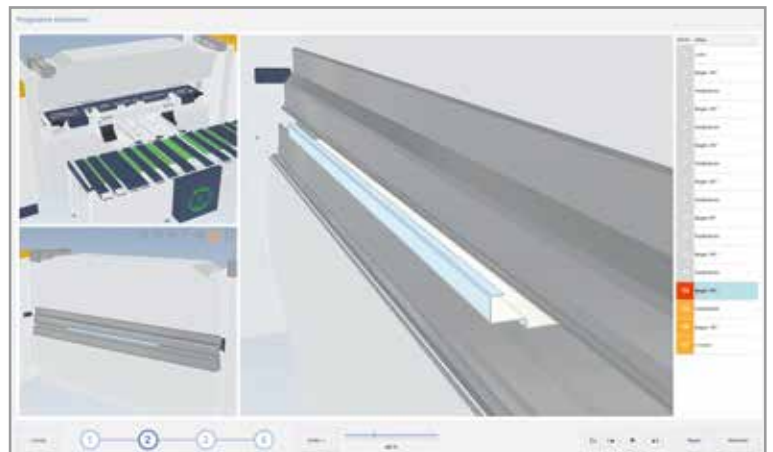

If the software finds alternative folding strategies, it proposes the best bending strategy using a five-star ranking system. A 3D simulation shows all details of the real bending sequence.

The **RAS ProfileCenter** bridges the gap between highly productive - but inflexible - rollforming lines and manually operated press brakes, which require a high level of operator expertise and great skill in the handling of the sheets.



## ProfileCenter

Technical Data	ProfileCenter
Material thickness max. (mild steel)	2.0 mm / 14 ga.
Material thickness max. (stainless)	1.5 mm / 16 ga.
Working length max.	3200 mm / 126"
Blank dimensions min.	100 x 600 mm / 4" x 23.5"
Blank dimensions max.	700 x 3200 mm / 27.5" x 126"
Z-bends min.	14.5 mm / 0.57"
One flange dimension min.	40 mm / 1.58"
Vacuum pump	incl.
Machine length	5500 mm / 217"
Machine depth	5500 mm / 217"
Machine height min./max.	2250/2700 mm / 88.5"/106"
Working height	1000 mm / 39.4"
Machine weight net about	15 000 kg / 33,100 lbs