

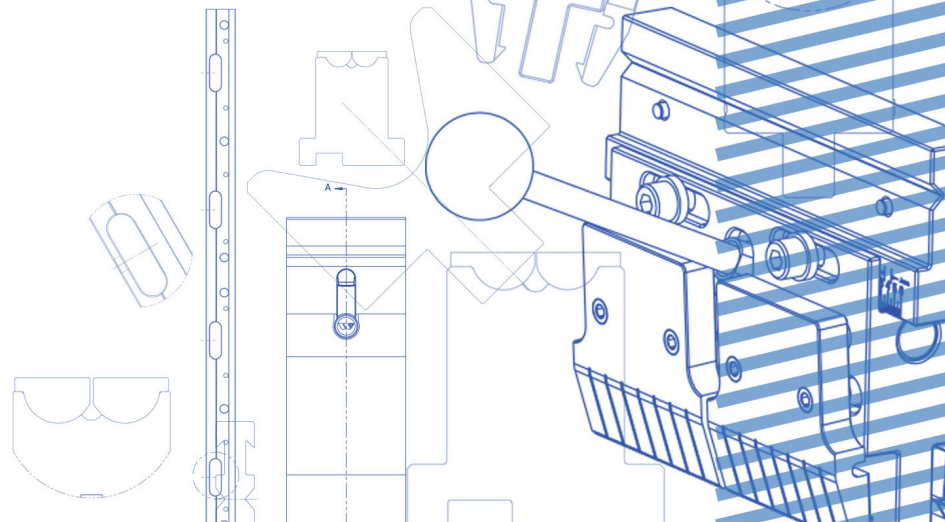

EURO STYLE PRESS BRAKE TOOLING SOLUTIONS

Standards, Specials and Accessories



PUNCHES

6

- 7 **Punch Profiles: Which one?**
- 8 90° Punches
- 12 88° Punches
- 17 85° Punches
- 26 75° Punches
- 20 60° Punches
- 22 45° Punches
- 23 35° Punches
- 24 30° Punches
- 27 26° Punches
- 28 Flattening Punches
- 29 Multi Radius Punches
- 30 Multi Radius Punch Inserts

DIES

31

- 32 **Die Profiles: Which one?**
- 33 Quick Change 1V Dies - 90°
- 35 Quick Change 1V Dies - 88°
- 37 Quick Change 1V Dies - 75°
- 38 Quick Change 1V Dies - 60°
- 39 Quick Change 1V Dies - 30°
- 41 T Section Dies - 90°
- 42 T Section Dies - 88°
- 43 T Section Dies - 85°
- 44 T Section Dies - 60°
- 45 T Section Dies - 45°
- 46 T Section Dies - 35°
- 47 T Section Dies - 30°
- 48 Quick Change 2V Dies - 90°
- 49 Quick Change 2V Dies - 88°
- 51 Quick Change 2V Dies - 60°
- 52 Quick Change 2V Dies - 30°
- 53 Bolt on 2V Dies - 90°
- 54 Bolt on 2V Dies - 88°
- 55 Bolt on 2V Dies - 60°
- 56 4V Dies
- 57 Large 1V Dies - 85°
- 59 Large 1V Dies - 80°
- 60 Large 1V Dies - 60°
- 61 Large 1V Dies - 45°
- 62 Large 1V Dies - 30°
- 63 V-Series Black
- 66 Hemming Dies -
Spring Loaded Replacement Vee
- 67 Hemming Dies - Spring Loaded
- 68 Hemming Sets - 2 Stage
- 69 3V Hemming Die
- 70 Urethane Pads and Holders
- 71 Offset

CONTENTS

HOLDERS

72

- 73 **Holders: Which one?**
- 74 1V Die Holders
- 76 2V Die Holders

CLAMPING

78

- 78 **Clamping Systems**
- 80 Basix Clamps
- 81 Basix + Clamps
- 82 Express Clamps
- 83 Express Clamps - Replacement Parts



SPECIALS 85

- 86 Custom Hemming
- 88 Offset Tools
- 89 Dies
- 90 Large Radii
- 91 Strengthening Rib. V-Rib
- 92 Forming
- 93 Stamping
- 94 Mechanical
- 98 Special Shape Punches
- 99 Holders
- 100 Wiping and Rotary Bending
- 101 Deep Box Bending. Swing Ears
- 102 Turret Adapter

ACCESSORIES 103

- 104 Extending Tool Life
- 105 Storage
- 106 Mark Free Bending
- 107 Press Brake Accessories
- 108 Digital Measuring Equipment

REFERENCE 109

- 109 Standard Punch and Die Lengths
- 110 Air Bending Force Chart

THE WILSON TOOL DIFFERENCE



Wilson Tool European Headquarters, UK



Wilson Tool France



Wilson Tool Denmark



Toolspress, Italy



Wilson Tool Germany

The Wilson Tool Punching Division continues to drive the industry with new levels of quality, delivery service and innovation.

From the early days of Series 80 tooling to Wilson Wheels to innovative EXP technology, our punching division has been the leading innovation driver in the industry. When combined with the most experienced customer support professionals in the industry, the solutions offered from Wilson Tool continue to raise the bar on performance and innovation. Thick turret, Trumpf, Salvagnini, or any other style of punch press you may be using, Wilson Tool offers the most complete line of tooling solutions available today.

PUNCHING

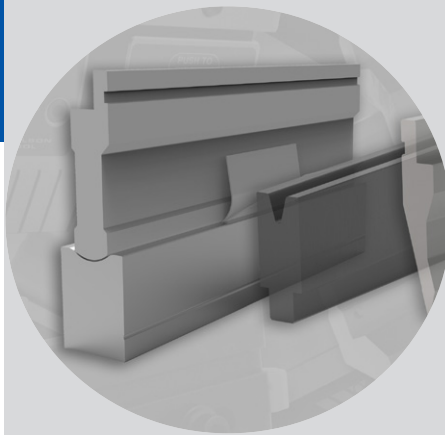

BENDING

Wilson Tool's Bending Division delivers the most complete line of tooling and clamping solutions available anywhere.

Whether you use European, Wila/Trumpf style precision tooling or conventional style tooling, Wilson Tool has a solution for you.

Our clamping options cover these styles as well. With hydraulic push button options, quick release mechanical options, or standard manual clamps, Wilson Tool has a clamping solution for any style of machine or budget. And our custom tooling manufacturing capabilities have quickly become the envy of the industry with innovative solutions for very complex bending challenges.

Wilson Tool's Stamping division (aka Impax Tooling Solutions) offers high quality punch and die components for the stamping industry.

Innovative products such as our Accu-Lock retainer inserts, and extensive coating options combined with our world-class customer service have enabled us to quickly grow into a world-class provider.

Our custom tooling expertise is second to none with many customers coming to us for their most difficult stamping challenges.

STAMPING



ACCESSORIES

Whether you need tool sharpening grinders, tooling storage systems, or other types of related supplies, our accessory products offer a wide range of solutions to help you be more productive.

From small to large items, our accessories will help your shop be more organized and efficient.



EURO STYLE PUNCHES



Wilson Tool European Style press brake punches are made to the strictest manufacturing standards using premium quality tool steels, guaranteeing the high-quality products our customers have come to expect.

An extensive range of Wilson Tool European style punches is held in stock with different tip radius in some cases. This means that many of the most popular punch options can be despatched on the same day they are ordered, or within one or two days if a modification is required.

Punch tip modifications and punch relief available	✓
All punches induction hardened	✓

PUNCH PROFILES - WHICH ONE?

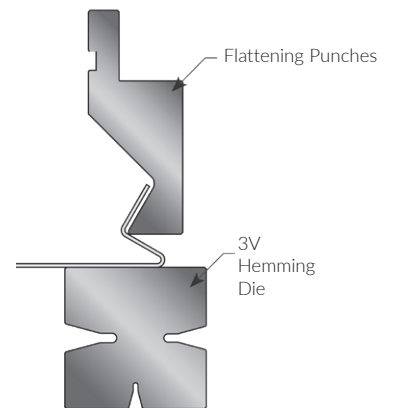
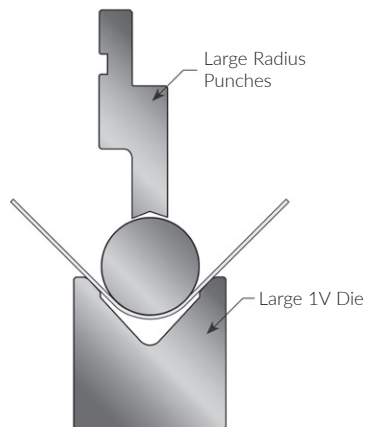
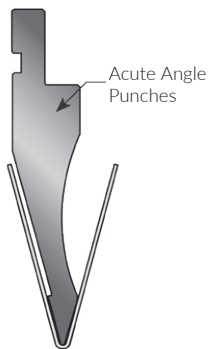
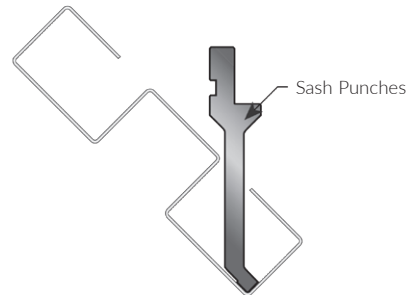
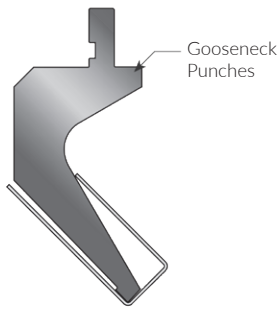
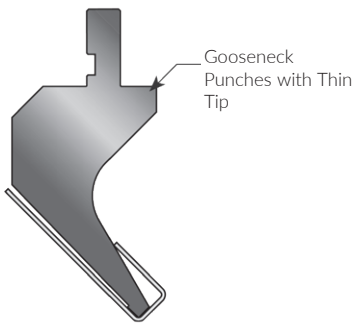
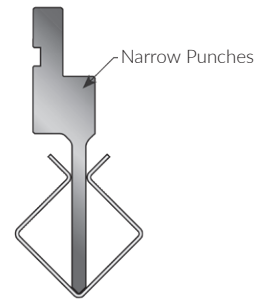
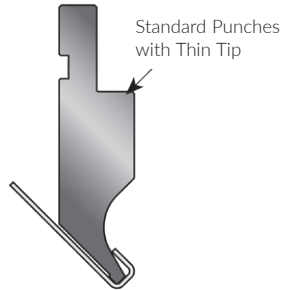
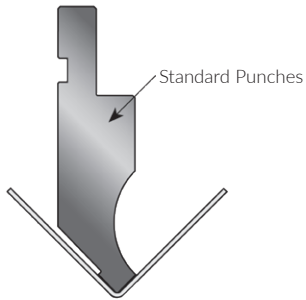

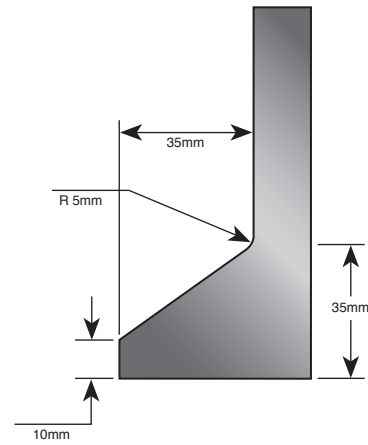
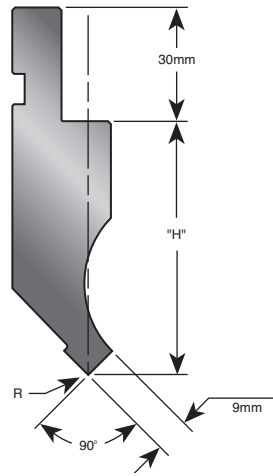

STANDARD 90° PUNCHES						
CAT. NO.	R mm	MAX. TON PER METRE	H mm	L 835 mm	S 415 mm	X 835 mm SECTIONALISED
E40102	0.2	100	66.9			
E40108	0.8	100	66.7			
E40115	1.5	100	66.4			
E40123	2.3	100	66.0			
E40130	3.0	100	65.7			

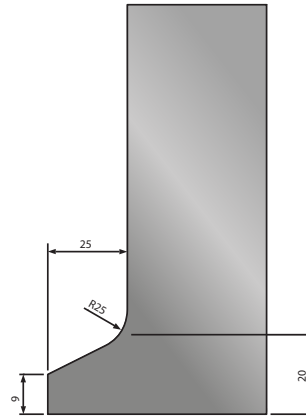
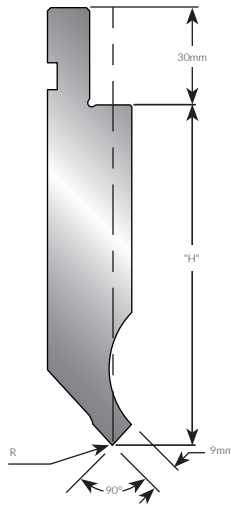

90° PUNCHES						
CAT. NO.	R mm	MAX. TON PER METRE	H mm	L 835 mm	S 415 mm	X 835 mm SECTIONALISED
E40110	0.2	100	104.9			
E40111	0.6	100	104.4			
E40112	0.8	100	104.7			

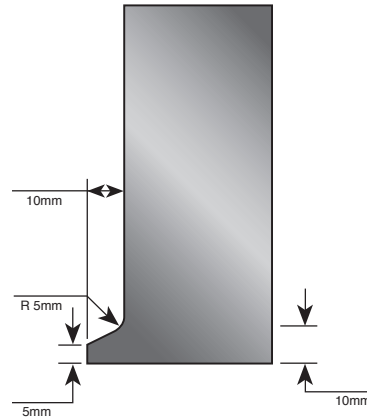
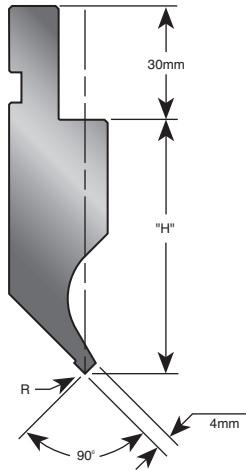

STANDARD 90° PUNCHES WITH THIN TIP						
CAT. NO.	R mm	MAX. TON PER METRE	H mm	L 835 mm	S 415 mm	X 835 mm SECTIONALISED
E40202	0.2	100	66.9			
E40206	0.6	100	66.4			

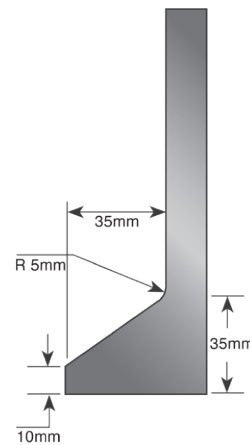
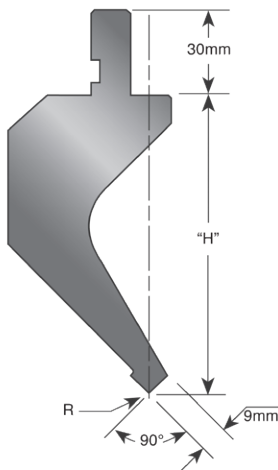

90° GOOSENECK PUNCHES						
CAT. NO.	R mm	MAX. TON PER METRE	H mm	L 835 mm	S 415 mm	X 835 mm SECTIONALISED
E44602	0.2	70	89.9			
E44606	0.6	70	89.4			
E44608	0.8	70	89.7			
E40502	0.2	50	104.9			
E40506	0.6	50	104.4			
E40508	0.8	50	104.7			
E44302	0.2	50	119.9			
E44306	0.6	50	119.4			
E44308	0.8	50	119.7			

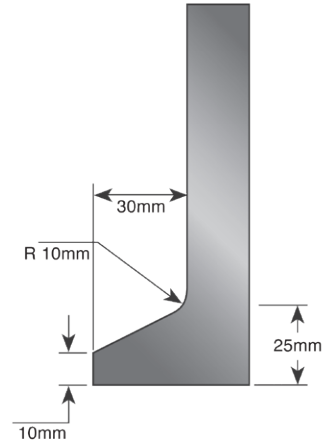
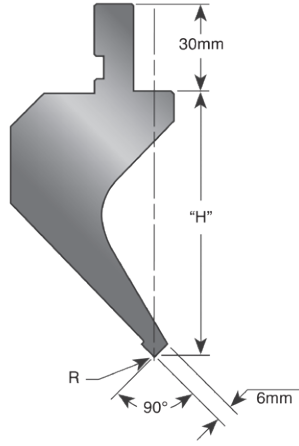

90° GOOSENECK PUNCHES WITH THIN TIP

CAT. NO.	R mm	MAX. TON PER METRE	H mm	L 835 mm	S 415 mm	X 835 mm SECTIONALISED
E40712	0.2	50	89.9			
E40716	0.6	50	89.4			
E40718	0.8	50	89.7			

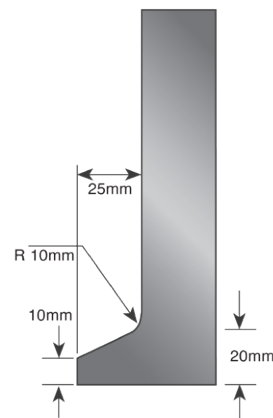
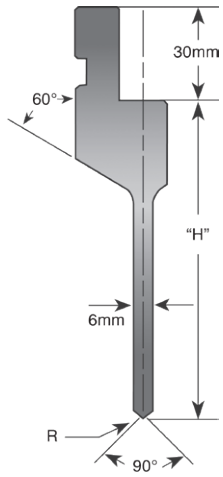

90° NARROW PUNCHES

CAT. NO.	R mm	MAX. TON PER METRE	H mm	L 835 mm	S 415 mm	X 835 mm SECTIONALISED
E40902	0.2	50	95.0			
E40906	0.6	50	94.4			
E40908	0.8	50	94.7			

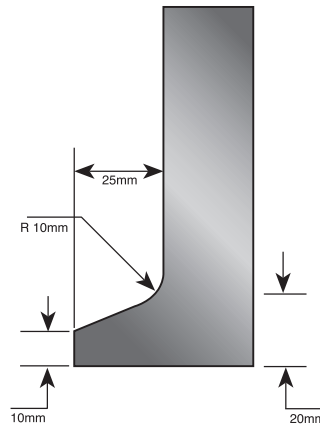
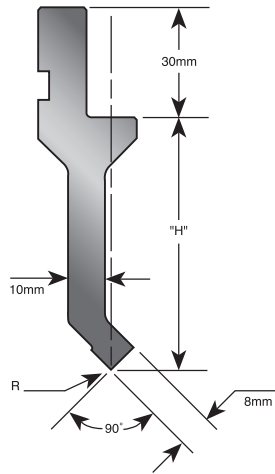

90° SASH PUNCHES

CAT. NO.	R mm	MAX. TON PER METRE	H mm	L 835 mm	S 415 mm	X 835 mm SECTIONALISED
E41202	0.2	30	69.9			
E41206	0.6	30	69.4			
E41208	0.8	30	69.7			
E41222	0.2	30	99.9			
E41226	0.6	30	99.4			
E41228	0.8	30	99.7			

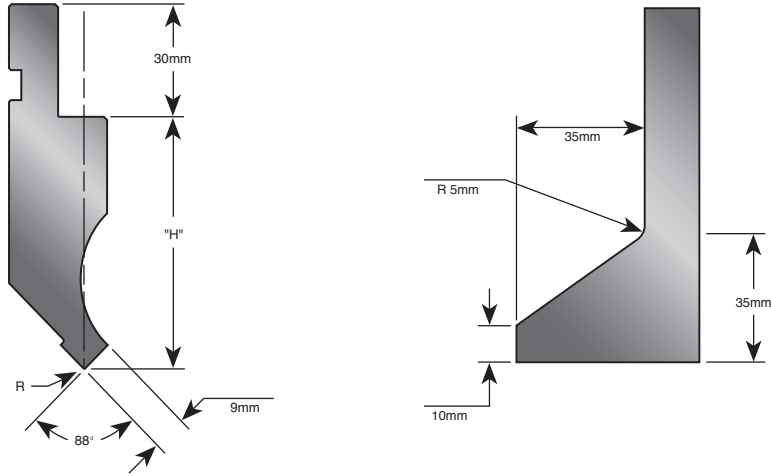

88° STANDARD PUNCHES						
CAT. NO.	R mm	MAX. TON PER METRE	H mm	L 835 mm	S 415 mm	X 835 mm SECTIONALISED
E40002	0.2	100	66.9			
E40006	0.6	100	66.4			
E40008	0.8	100	66.6			
E40015	1.5	100	66.3			
E40023	2.3	100	66.0			
E40030	3.0	100	65.7			

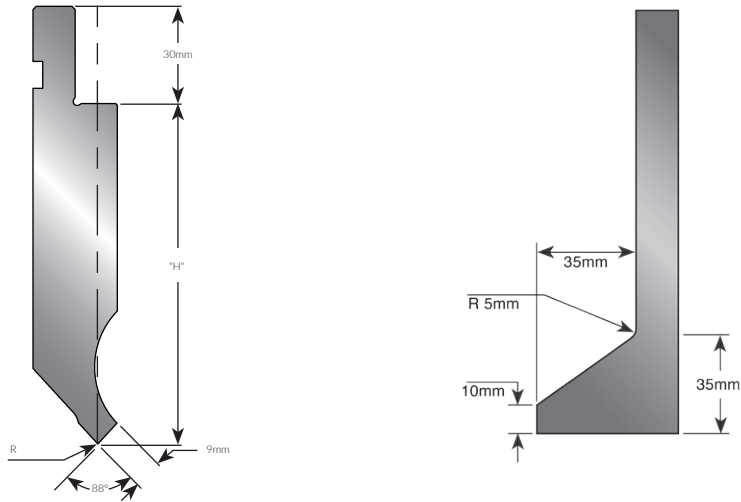

88° PUNCHES						
CAT. NO.	R mm	MAX. TON PER METRE	H mm	L 835 mm	S 415 mm	X 835 mm SECTIONALISED
E40140	0.2	100	104.9			
E40141	0.6	100	104.4			
E40142	0.8	100	104.7			
E40143	1.5	100	104.3			
E40144	3.0	100	103.7			

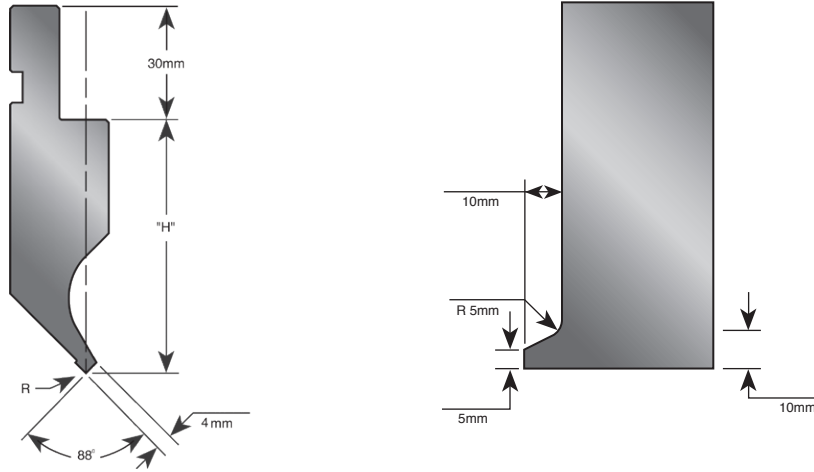

88° STANDARD PUNCHES WITH THIN TIP

CAT. NO.	R mm	MAX. TON PER METRE	H mm	L 835 mm	S 415 mm	X 835 mm SECTIONALISED
E40212	0.2	100	66.9			
E40216	0.6	100	66.4			
E40218	0.8	100	66.6			

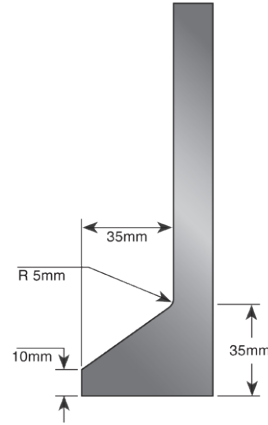
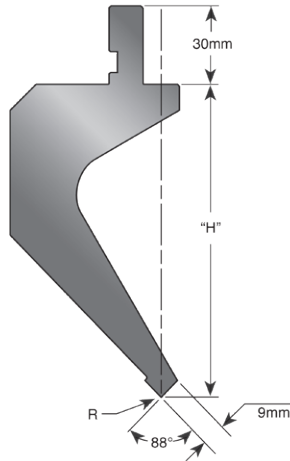

88° GOOSENECK PUNCHES

CAT. NO.	R mm	MAX. TON PER METRE	H mm	L 835 mm	S 415 mm	X 835 mm SECTIONALISED
E40602	0.2	70	89.9			
E40606	0.6	70	89.4			
E40608	0.8	70	89.6			
E40615	1.5	70	89.3			
E40630	3.0	70	88.7			
E40402	0.2	50	104.9			
E40406	0.6	50	104.4			
E40408	0.8	50	104.6			
E40415	1.5	50	104.3			
E40430	3.0	50	103.7			
E40302	0.2	50	119.9			
E40306	0.6	50	119.4			
E40308	0.8	50	119.65			
E40315	1.5	50	119.3			
E40330	3.0	50	118.7			
E40104	0.6	50	144.4			
E40105	0.8	50	145.0			
E40103	0.6	50	159.4			
E40106	0.8	50	159.65			

88° TALL GOOSENECK PUNCHES

CAT. NO.	R mm	MAX. TON PER METRE	H mm	L 505 mm	X 835 mm SECTIONALISED
E41558-505	0.8	80	200.0		

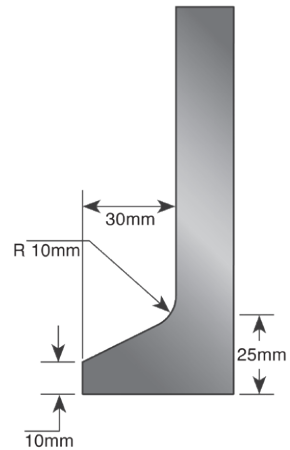
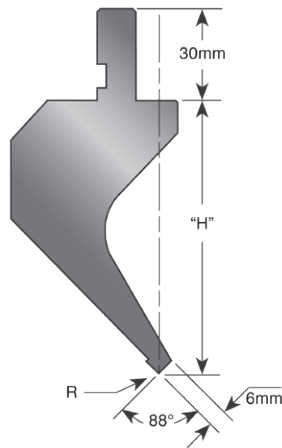

88° GOOSENECK PUNCHES WITH THIN TIP

CAT. NO.	R mm	MAX. TON PER METRE	H mm	L 835 mm	S 415 mm	X 835 mm SECTIONALISED
E40702	0.2	50	89.9			
E40706	0.6	50	89.4			
E40708	0.8	50	89.6			
E40709	1.5	50	89.3			
E40710	3.0	50	88.7			

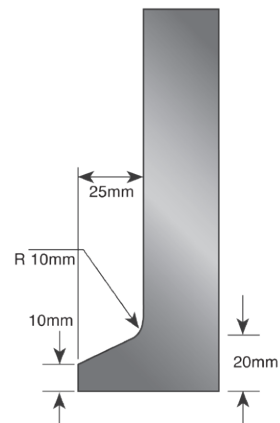
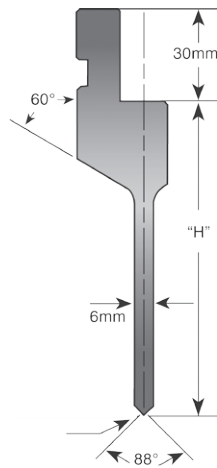

88° NARROW PUNCHES

CAT. NO.	R mm	MAX. TON PER METRE	H mm	L 835 mm	S 415 mm	X 835 mm SECTIONALISED
E40802	0.2	50	95.0			
E40806	0.6	50	94.5			
E40808	0.8	50	94.7			
E41636	0.6	50	159.4			
E41638	0.8	50	159.7			

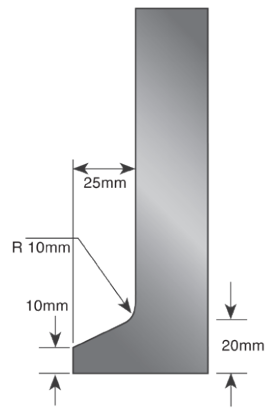
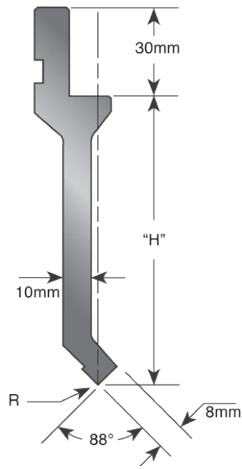

88° SASH PUNCHES

CAT. NO.	R mm	MAX. TON PER METRE	H mm	L 835 mm	S 415 mm	X 835 mm SECTIONALISED
E41102	0.2	30	69.9			
E41106	0.6	30	69.4			
E41108	0.8	30	69.7			
E41002	0.2	30	99.9			
E41006	0.6	30	99.4			
E41008	0.8	30	99.7			

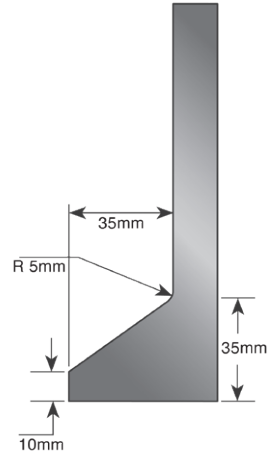
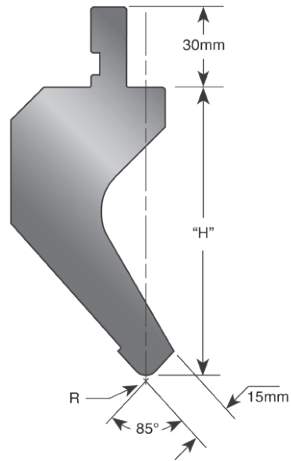

85° GOOSENECK PUNCHES

CAT. NO.	R mm	MAX. TON PER METRE	H mm	L 835 mm	S 415 mm	X 835 mm SECTIONALISED
E44540	4.8	100	105.0			
E44560	6.4	100	104.3			

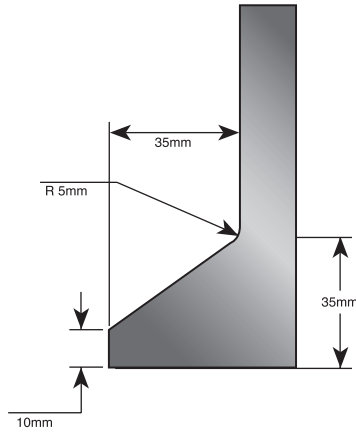
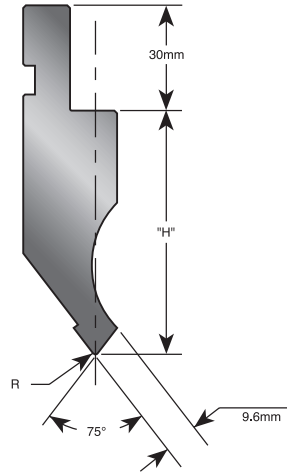

75° STANDARD PUNCHES

CAT. NO.	R mm	MAX. TON PER METRE	H mm	L 835 mm	S 415 mm	X 835 mm SECTIONALISED
E44000	0.8	100	67.6			
E44001	1.5	100	67.2			
E44003	3.0	100	66.2			

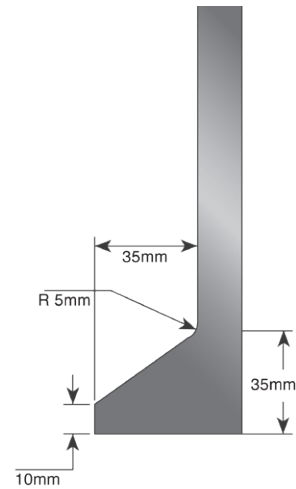
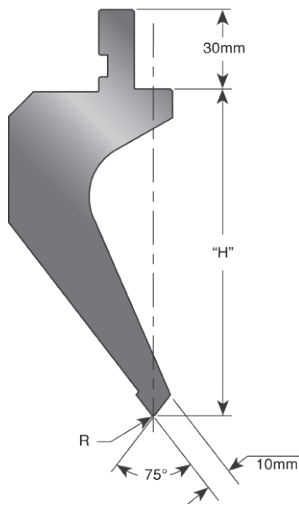

75° GOOSENECK PUNCHES

CAT. NO.	R mm	MAX. TON PER METRE	H mm	L 835 mm	S 415 mm	X 835 mm SECTIONALISED
E44020	0.8	70	90.8			
E44021	1.5	70	89.5			
E44023	3.0	70	88.6			
E44030	0.8	50	120.0			
E44031	1.5	50	119.5			
E44033	3.0	50	118.6			

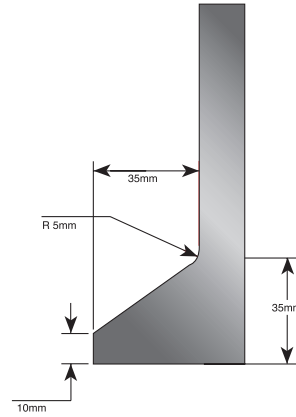
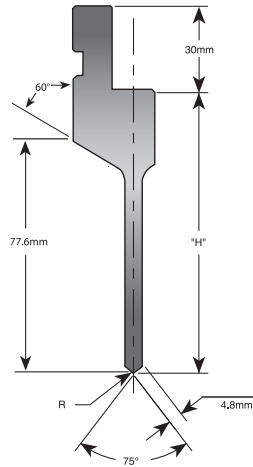

75° NARROW PUNCHES

CAT. NO.	R mm	MAX. TON PER METRE	H mm	L 835 mm	S 415 mm	X 835 mm SECTIONALISED
E44010	0.8	50	95.0			
E44011	1.5	50	94.5			
E44013	3.0	50	93.6			

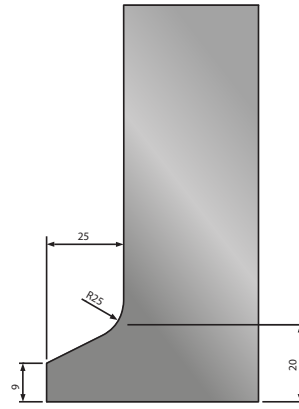
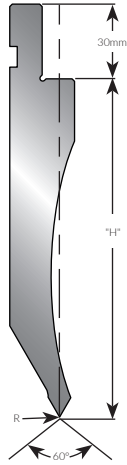

60° PUNCHES						
CAT. NO.	R mm	MAX. TON PER METRE	H mm	L 835 mm	S 415 mm	X 835 mm SECTIONALISED
E41507	0.8	100	135.0			
E41508	2.0	100	133.8			

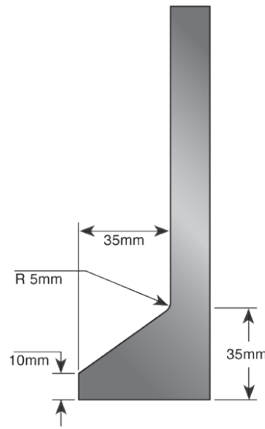
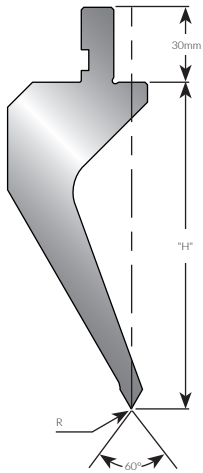

60° GOOSENECK PUNCHES						
CAT. NO.	R mm	MAX. TON PER METRE	H mm	L 835 mm	S 415 mm	X 835 mm SECTIONALISED
E41500	0.8	60	105.0			
E41501	2.0	60	103.8			
E41502	0.8	60	130.0			
E41503	2.0	60	128.8			
E41506	0.8	50	160.0			

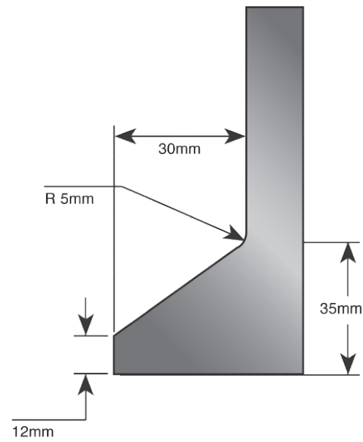
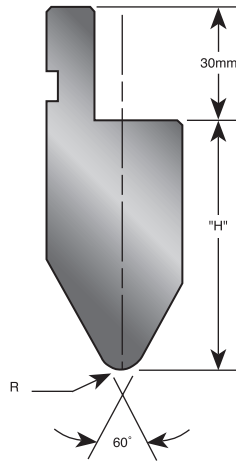

60° ACUTE ANGLE PUNCHES						
CAT. NO.	R mm	MAX. TON PER METRE	H mm	L 835 mm	S 415 mm	X 835 mm SECTIONALISED
E41440	4.8	100	66.2			
E41460	6.0	100	65.0			

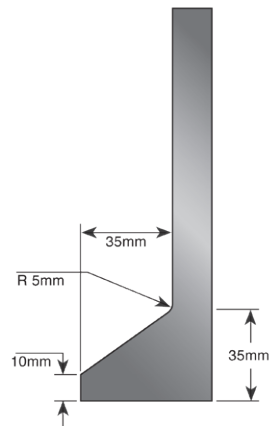
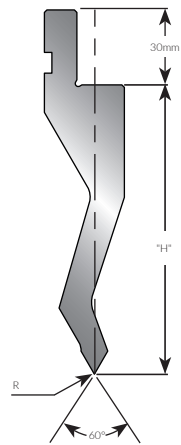

60° DOUBLE RELIEF PUNCH						
CAT. NO.	R mm	MAX. TON PER METRE	H mm	L 835 mm	S 415 mm	X 835 mm SECTIONALISED
E41504	0.8	60	115.0			
E41505	2.0	60	113.8			

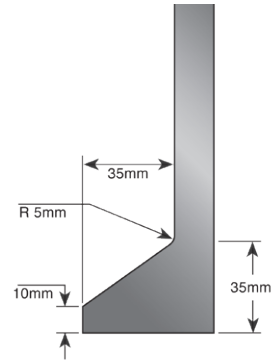
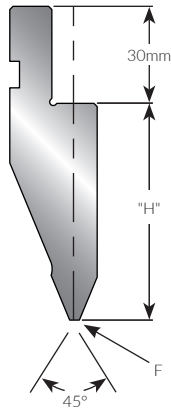

45° ACUTE ANGLE PUNCH WITH FLAT

CAT. NO.	F mm	MAX. TON PER METRE	H mm	L 835 mm	S 415 mm	X 835 mm SECTIONALISED
E41601	3	100	67			

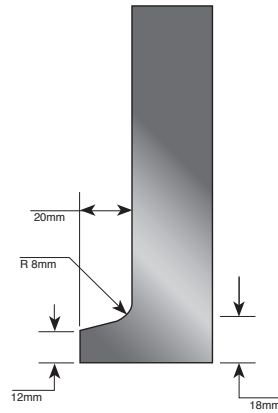
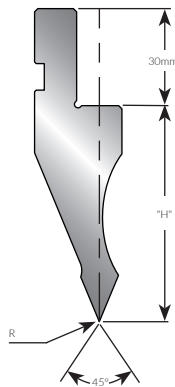

45° ACUTE ANGLE PUNCH WITH RECESS

CAT. NO.	R mm	MAX. TON PER METRE	H mm	L 835 mm	S 415 mm	X 835 mm SECTIONALISED
E41600	0.4	100	66.4			

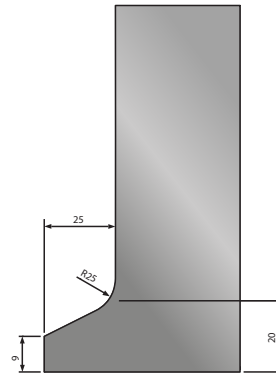
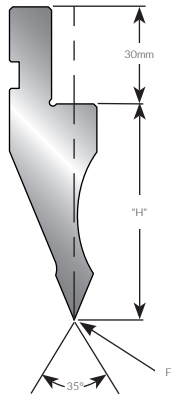

35° ACUTE ANGLE PUNCH WITH RECESS						
CAT. NO.	F mm	MAX. TON PER METRE	H mm	L 835 mm	S 415 mm	X 835 mm SECTIONALISED
E41602	0.8	100	90			

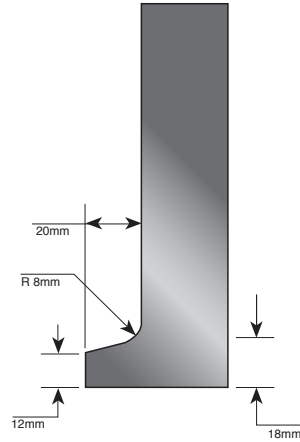
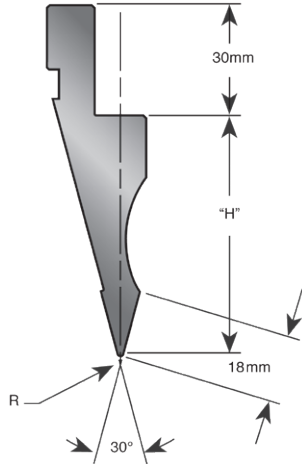

30° ACUTE ANGLE PUNCH WITH RECESS

CAT. NO.	R mm	MAX. TON PER METRE	H mm	L 835 mm	S 415 mm	X 835 mm SECTIONALISED
E42610	0.8	100	65.5			

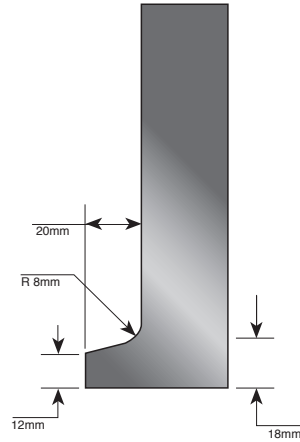
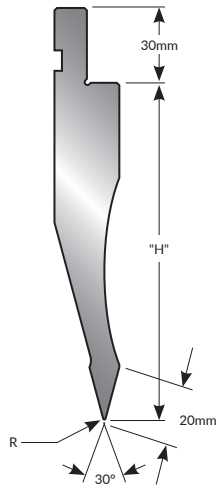

30° ACUTE ANGLE PUNCHES

CAT. NO.	R mm	MAX. TON PER METRE	H mm	L 835 mm	S 415 mm	X 835 mm SECTIONALISED
E42603	0.5	100	135.0			

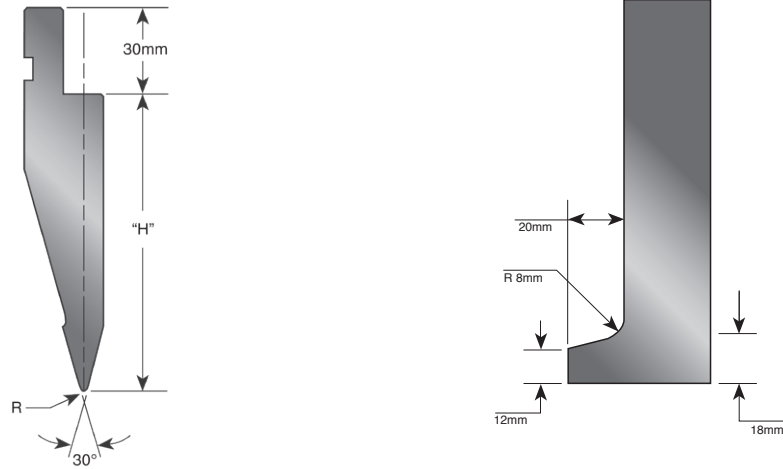

30° ACUTE ANGLE PUNCHES WITH FLAT BACK						
CAT. NO.	R mm	MAX. TON PER METRE	H mm	L 835 mm	S 415 mm	X 835 mm SECTIONALISED
E41306	0.65	100	104.0			
E41307	0.8	100	104.0			
E41315	1.5	100	102.0			
E41330	3.0	100	97.7			

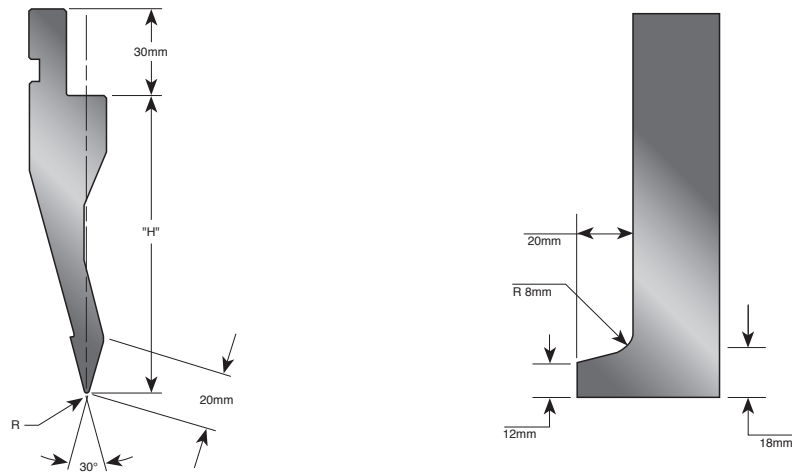

30° ACUTE ANGLE PUNCH WITH RECESS						
CAT. NO.	R mm	MAX. TON PER METRE	H mm	L 835 mm	S 415 mm	X 835 mm SECTIONALISED
E41908	0.8	100	104.0			

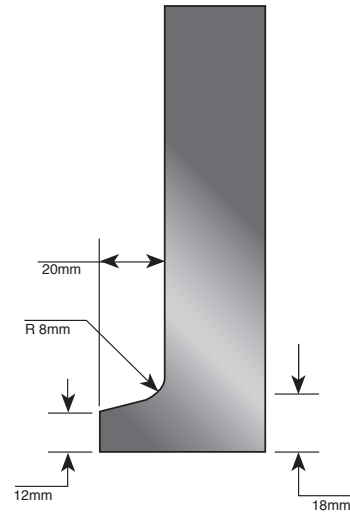
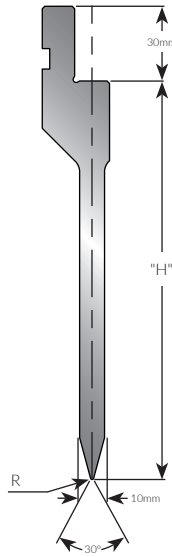

30° NARROW PUNCH

CAT. NO.	R mm	MAX. TON PER METRE	H mm	L 835 mm	S 415 mm	X 835 mm SECTIONALISED
E41604	0.65	50	160.0			

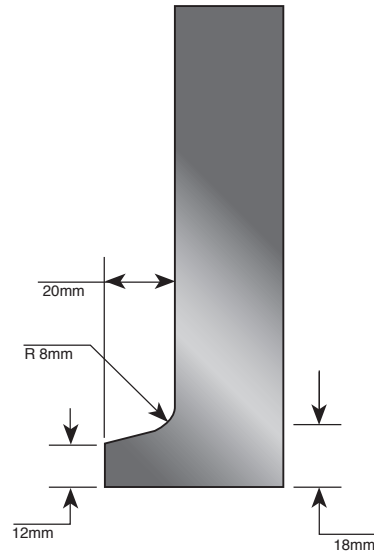
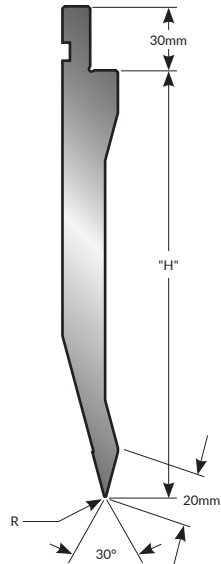

30° TALL ACUTE ANGLE WITH RECESS

CAT. NO.	R mm	MAX. TON PER METRE	H mm	L 835 mm	S 415 mm	X 835 mm SECTIONALISED
E41605	0.5	50	200.0			

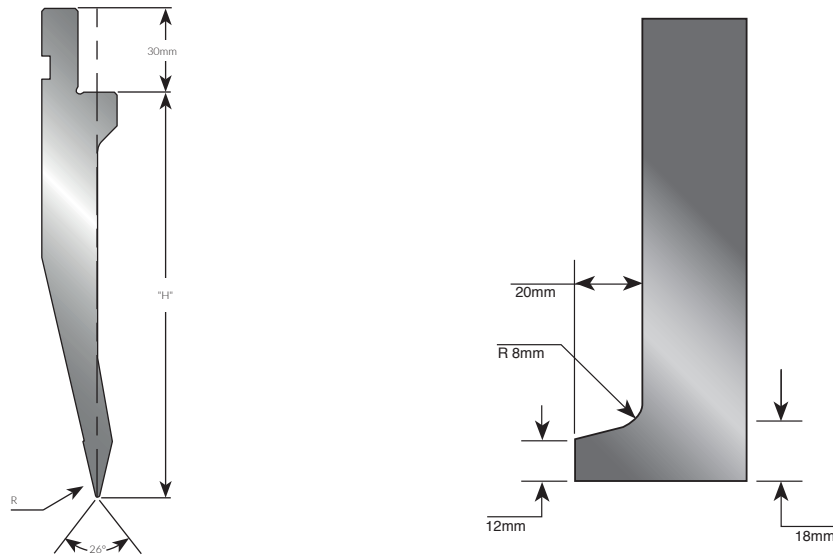

26° ACUTE ANGLE PUNCH

CAT. NO.	R mm	MAX. TON PER METRE	H mm	L 835 mm	S 415 mm	X 835 mm SECTIONALISED
E41615	0.8	90	145.0			

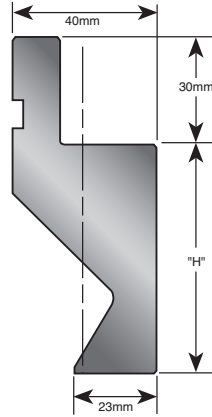

FLATTENING PUNCHES					
CAT. NO.	MAX. TON PER METRE	H mm	L 835 mm	S 415 mm	X 835 mm SECTIONALISED
E41523	100	65.0			

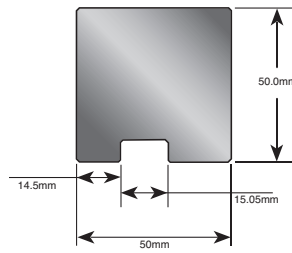

QUICK CHANGE RAIL STYLE FLATTENING DIE					
CAT. NO.	MAX. TON PER METRE	H mm	LT 835 mm	ST 415 mm	XT 835 mm SECTIONALISED
42312	100	50.0			

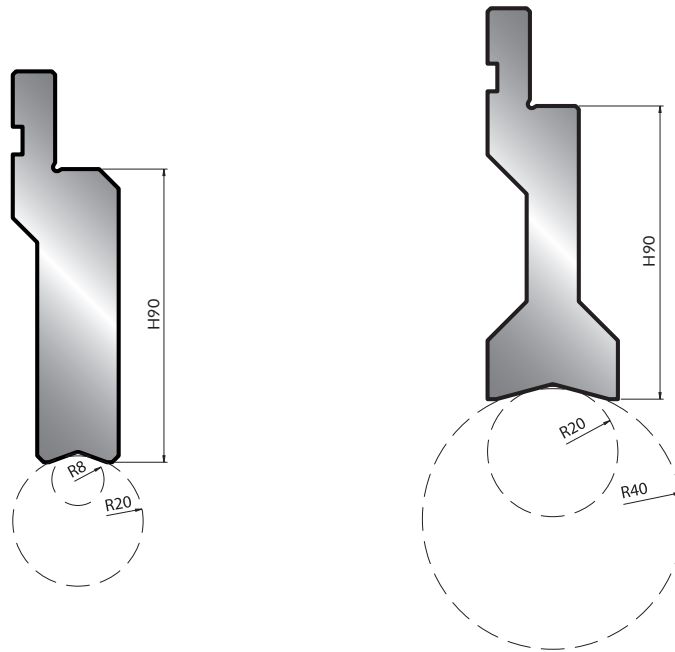

100T/MTR ON ALL TOOLS

CAT. NO.	PRICE
E408T25-835	
E408T25-500	
E408T25-300	
E408T25-200	
E408T25-100	
E408T25-250X	
E408T40-835	
E408T40-500	
E408T40-300	
E408T40-200	
E408T40-100	
E408T40-250X	

*Note: Hardware included in punch bodies.
 Bodies and Inserts Induction Hardened.
 250 X Sectionalised to: 25,25,30,35,40,45,50.

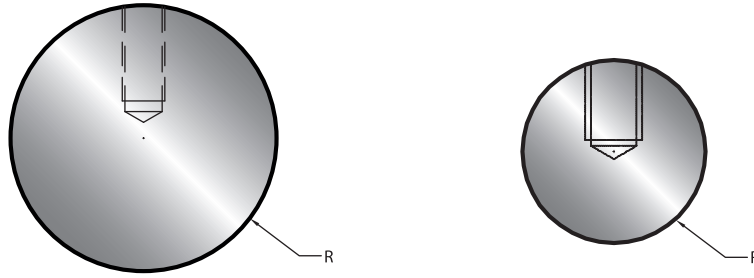

	L 835 mm	L 500 mm	L 300 mm	L 200 mm	L 100 mm	L 250x mm
R 8 mm	E4R080-835	E4R080-500	E4R080-300	E4R080-200	E4R080-100	E4R080-250x
R 10 mm	E4R100-835	E4R100-500	E4R100-300	E4R100-200	E4R100-100	E4R100-250x
R 12.5 mm	E4R125-835	E4R125-500	E4R125-300	E4R125-200	E4R125-100	E4R125-250x
R 15 mm	E4R150-835	E4R150-500	E4R150-300	E4R150-200	E4R150-100	E4R150-250x
R 17.5 mm	E4R175-835	E4R175-500	E4R175-300	E4R175-200	E4R175-100	E4R175-250x
R 20 mm	E4R200-835	E4R200-500	E4R200-300	E4R200-200	E4R200-100	E4R200-250x
R 25 mm	E4R250-835	E4R250-500	E4R250-300	E4R250-200	E4R250-100	E4R250-250x
R 30 mm	E4R300-835	E4R300-500	E4R300-300	E4R300-200	E4R300-100	E4R300-250x
R 35 mm	E4R350-835	E4R350-500	E4R350-300	E4R350-200	E4R350-100	E4R350-250x
R 40 mm	E4R400-835	E4R400-500	E4R400-300	E4R400-200	E4R400-100	E4R400-250x



Wilson Tool offers a comprehensive range of European style press brake dies including; single V, double V, quick change, bolt-on style, 4-V dies and many more. All dies up to 25mm V-opening are made with our exclusive Nitrex surface enhancement as standard and many models are held in stock for same day shipment.

NITREX

Nitrex™ high endurance surface enhancement, exclusively from Wilson Tool, increases press brake tooling life by several times that of standard tooling. With a surface hardness of HRC-70 and a consistent 0.5mm of penetration below the surface of the tool, Nitrex™ adds lubricity to press brake tooling and lowers the coefficient of friction as the material slides over the shoulder of the V-opening on a die. Any Wilson Tool press brake punch or die can be enhanced with Nitrex™.



DIE PROFILES - WHICH ONE?

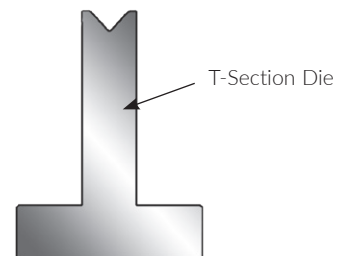
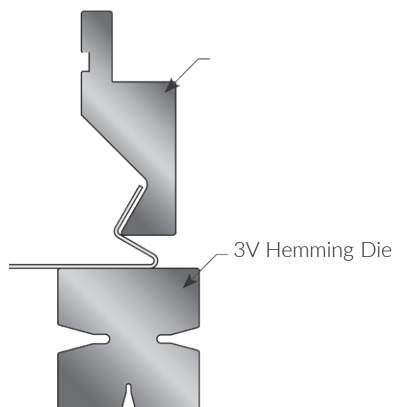
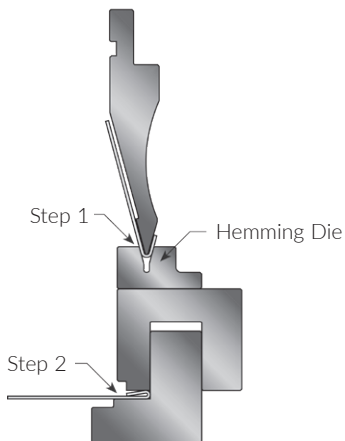
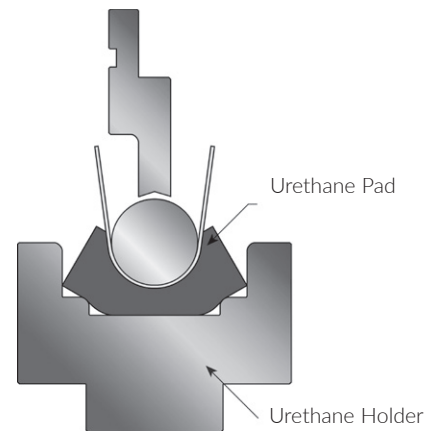
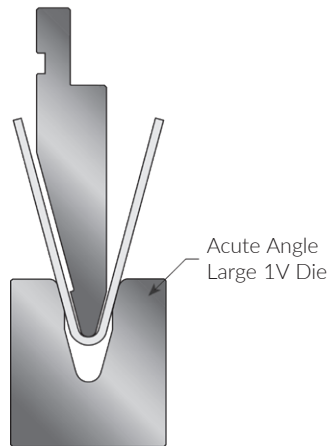
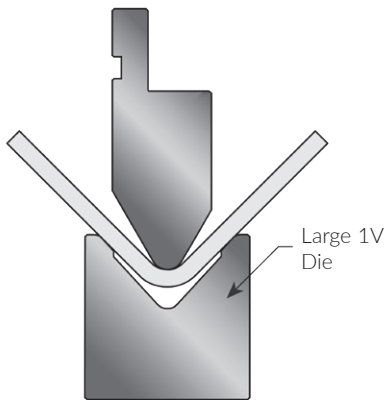
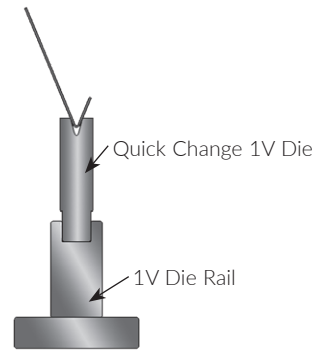
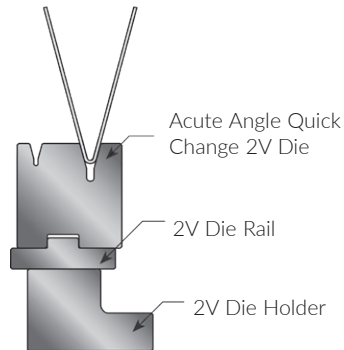
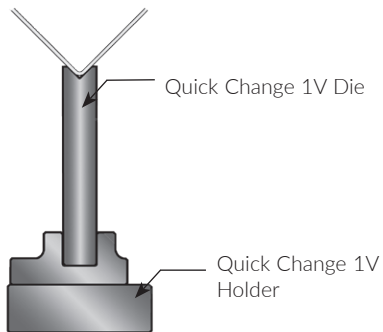
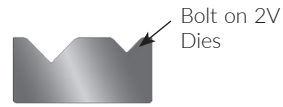
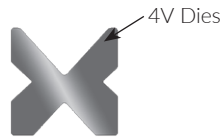

Cat. No. E42801

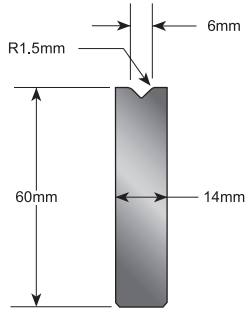

Cat. No. E42802

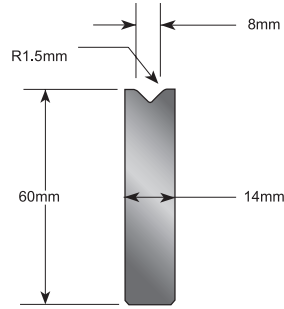

Cat. No. E42803

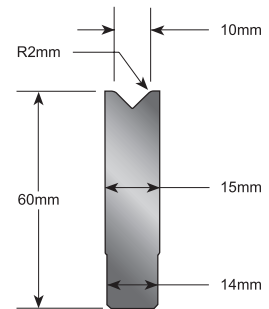

Cat. No. E42804

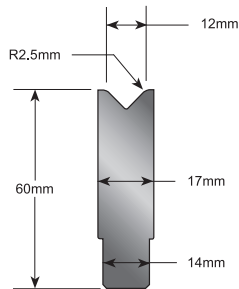

Cat. No. E42805

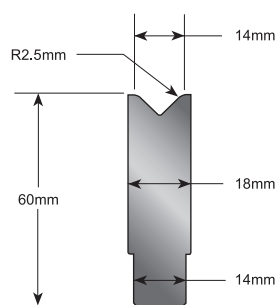

90° 1V DIES QC							
CAT. NO.	MAX. TON PER METER	V OPENING	R mm	H mm	L 835 mm	S 415 mm	X 835 mm SECTIONALISED
E42801	100	6	1.5	60			
E42802	100	8	1.5	60			
E42803	100	10	2.0	60			
E42804	100	12	2.5	60			
E42805	100	14	2.5	60			

Nitrex as standard

Cat. No. 42100

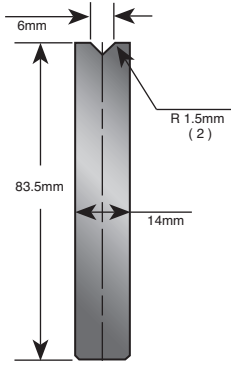

Cat. No. 42101

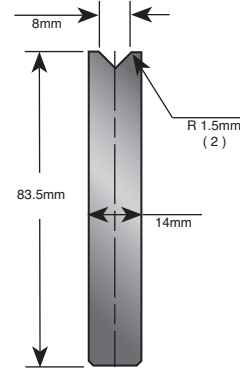

Cat. No. 42102

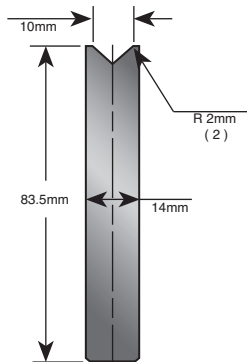

Cat. No. 42103

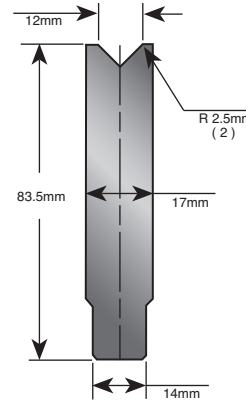
90° 1V DIES QC

CAT. NO.	MAX. TON PER METRE	V OPENING	R mm	H mm	LT 835 mm	ST 415 mm	XT 835 mm SECTIONALISED
42100	100	6	1.5	83.5			
42101	100	8	1.5	83.5			
42102	100	10	2.0	83.5			
42103	100	12	2.5	83.5			

Nitrex as standard

Cat. No. E42821

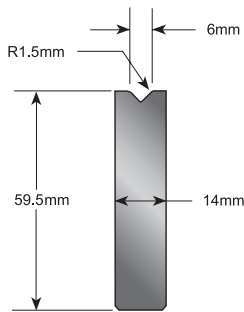

Cat. No. E42822

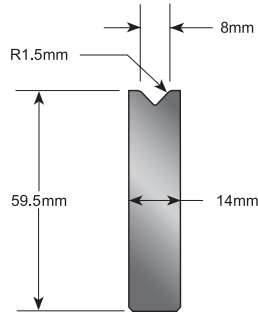

Cat. No. E42823

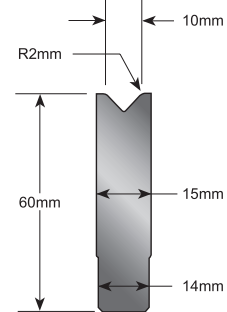

Cat. No. E42824

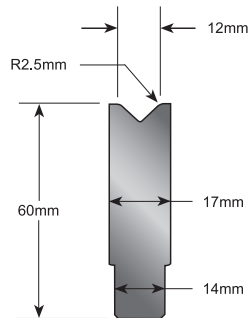

Cat. No. E42825

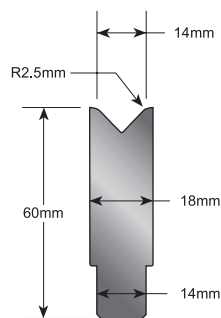

Cat. No. E42826

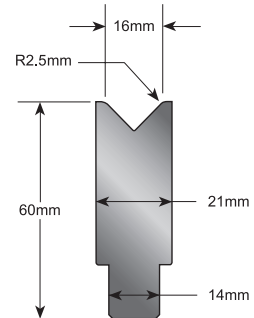

Cat. No. E42827

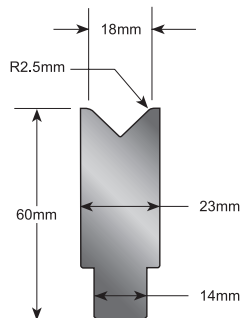

Cat. No. E42828

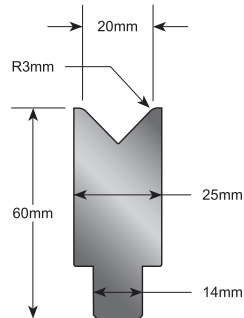

Cat. No. E42829

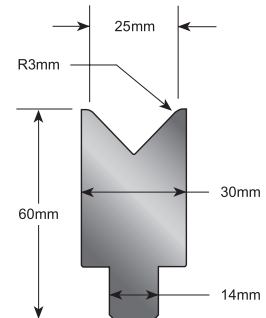

88° 1V DIES QC							
CAT. NO.	MAX. TON PER METRE	V OPENING	R mm	H mm	L 835 mm	S 415 mm	X 835 mm SECTIONALISED
E42821	100	6	1.5	59.5			
E42822	100	8	1.5	59.5			
E42823	100	10	2.0	60.0			
E42824	100	12	2.5	60.0			
E42825	100	14	2.5	60.0			
E42826	100	16	2.5	60.0			
E42827	100	18	2.5	60.0			
E42828	100	20	3.0	60.0			
E42829	100	25	3.0	60.0			

Nitrex as standard

Cat. No. 42120

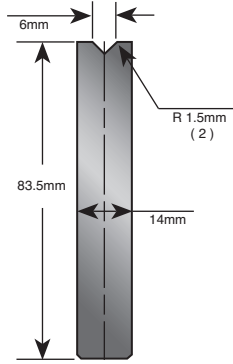

Cat. No. 42121

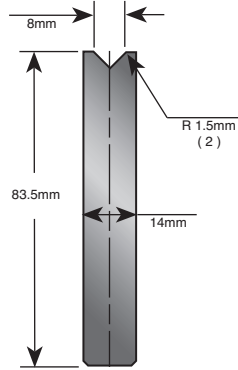

Cat. No. 42122

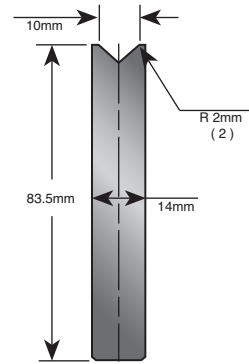

Cat. No. 42104

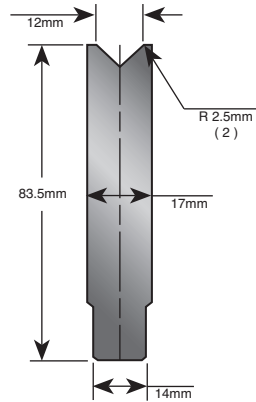

Cat. No. 42105

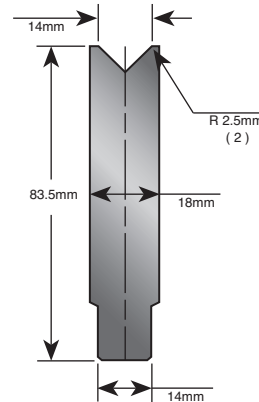

88° 1V DIES QC

CAT. NO.	MAX. TON PER METRE	V OPENING	R mm	H mm	LT 835 mm	ST 415 mm	XT 835 mm SECTIONALISED
42120	100	6	1.5	83.5			
42121	100	8	1.5	83.5			
42122	100	10	2.0	83.5			
42104	100	12	2.5	83.5			
42105	100	14	2.5	83.5			

Nitrex as standard

Cat. No. 44200

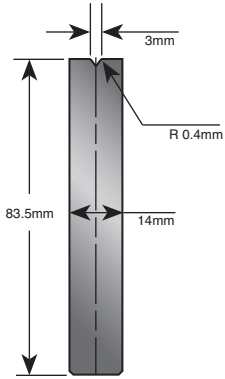

Cat. No. 44201

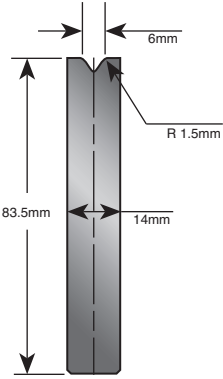

Cat. No. 44202

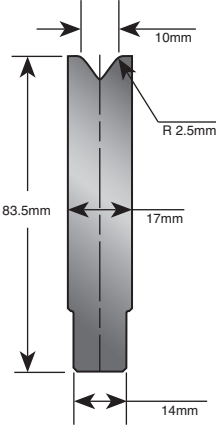

Cat. No. 44203

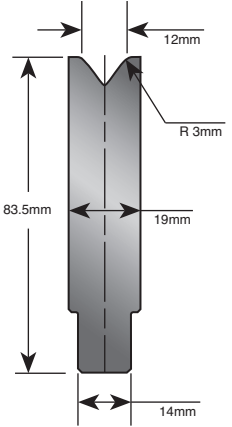

Cat. No. 44204

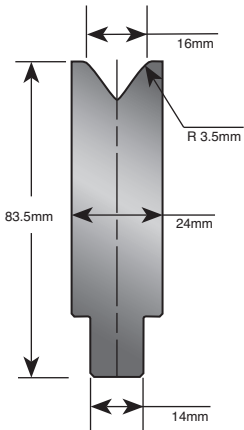

Cat. No. 44205

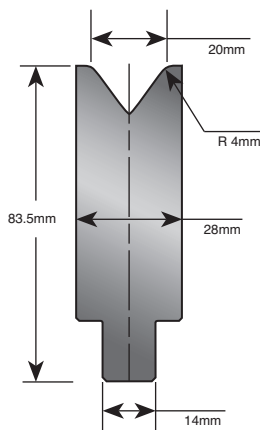

Cat. No. 44206

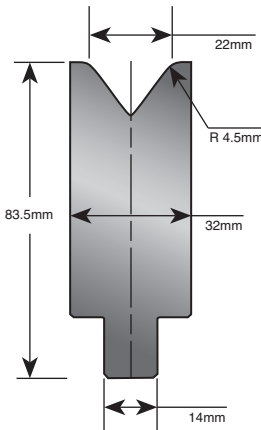

Cat. No. 44207

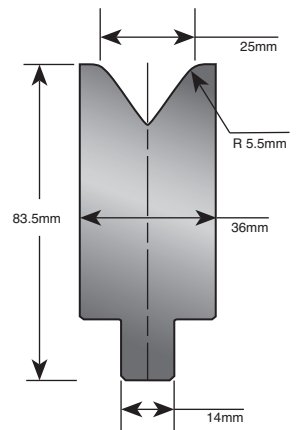

75° 1V DIES QC							
CAT. NO.	MAX. TON PER METRE	V OPENING	R mm	H mm	LT 835 mm	ST 415 mm	XT 835 mm SECTIONALISED
44200	100	3	0.4	83.5			
44201	100	6	1.5	83.5			
44202	100	10	2.5	83.5			
44203	100	12	3.0	83.5			
44204	100	16	3.5	83.5			
44205	100	20	4.0	83.5			
44206	100	22	4.5	83.5			
44207	100	25	5.5	83.5			

Nitrex as standard

Cat. No. E42160

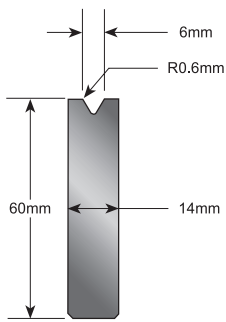

Cat. No. E42161

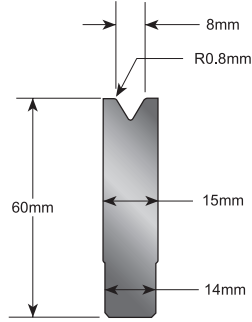

Cat. No. E42162

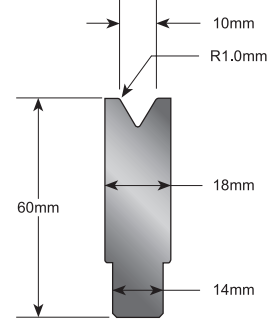

Cat. No. E42163

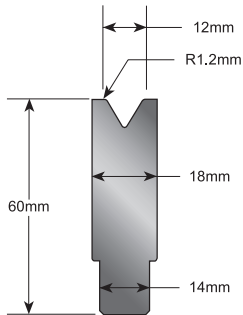

Cat. No. E42164

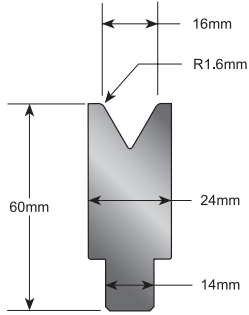

Cat. No. E42165

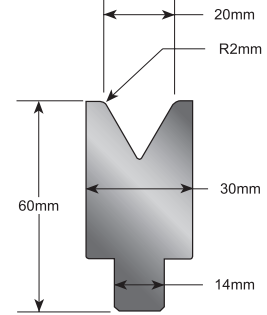

Cat. No. E42166

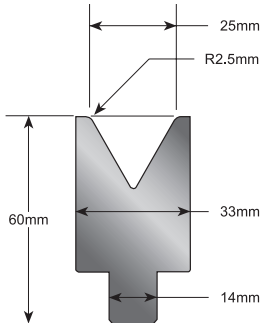

60° 1V DIES QC							
CAT. NO.	MAX. TON PER METRE	V OPENING	R mm	H mm	L 835 mm	S 415 mm	X 835 mm SECTIONALISED
E42160	60	6	0.6	60			
E42161	60	8	0.8	60			
E42162	60	10	1.0	60			
E42163	60	12	1.2	60			
E42164	60	16	1.6	60			
E42165	60	20	2.0	60			
E42166	60	25	2.5	60			

Nitrex as standard

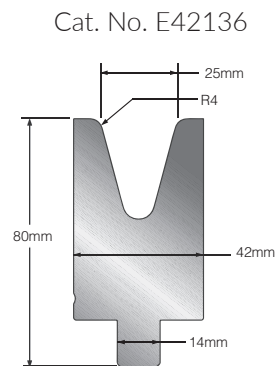
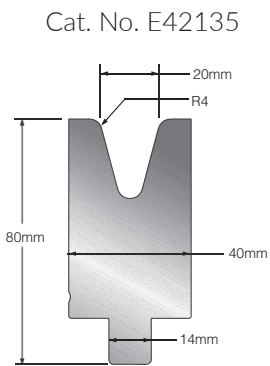
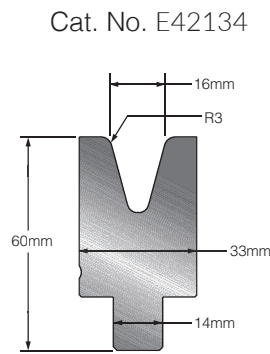
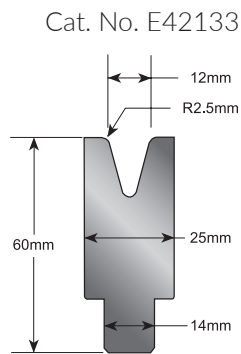
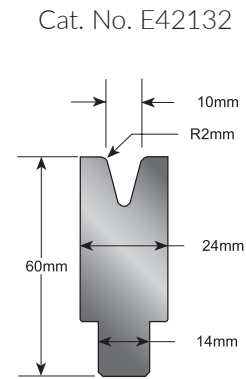
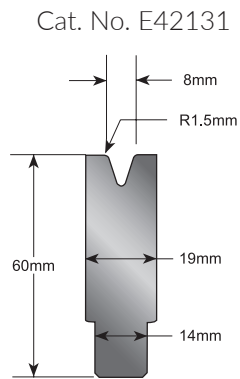
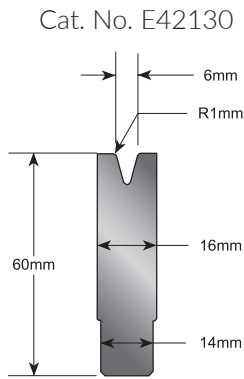

30° 1V DIES QC							
CAT. NO.	MAX. TON PER METRE	V OPENING	R mm	H mm	L 835 mm	S 415 mm	X 835 mm SECTIONALISED
E42130	40	6	1.0	60			
E42131	60	8	1.5	60			
E42132	60	10	2.0	60			
E42133	60	12	2.5	60			
E42134	60	16	3.0	60			
E42135	60	20	4.0	80			
E42136	60	25	4.0	80			

Nitrex as standard

Cat. No. 42200

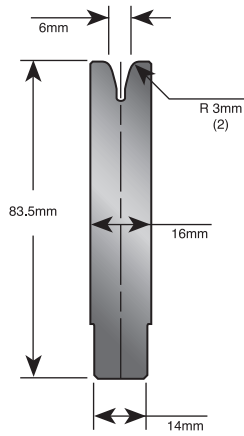

Cat. No. 42201

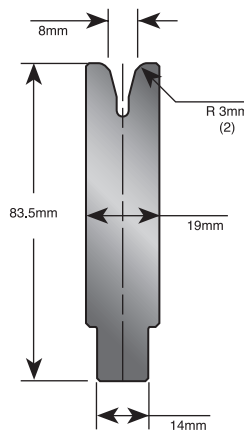

Cat. No. 42202

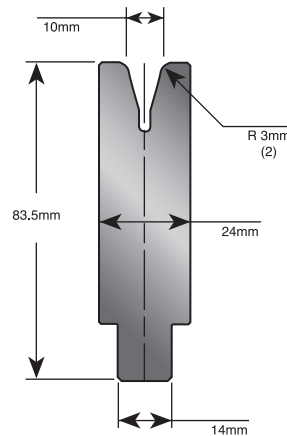

Cat. No. 42203

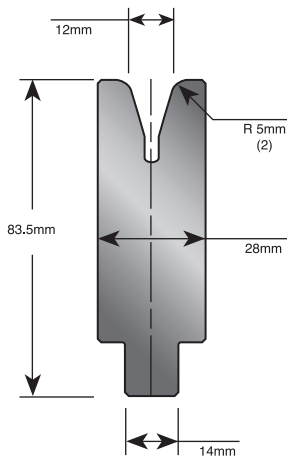

Cat. No. 42204

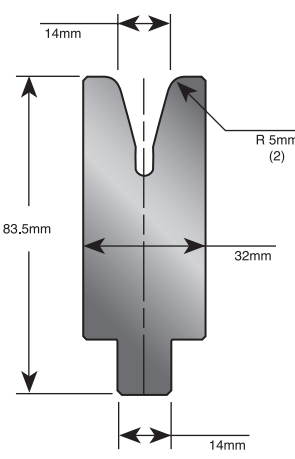

Cat. No. 42205

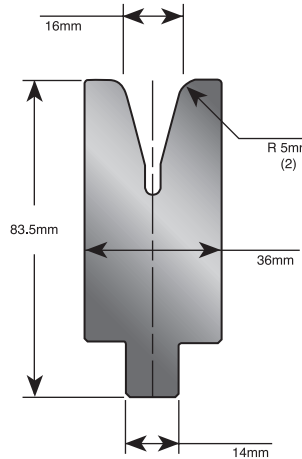

30° 1V DIES QC

CAT. NO.	MAX. TON PER METRE	V OPENING	R mm	H mm	LT 835 mm	ST 415 mm	XT 835 mm SECTIONALISED
42200	100	6	3.0	83.5			
42201	100	8	3.0	83.5			
42202	100	10	3.0	83.5			
42203	100	12	5.0	83.5			
42204	100	14	5.0	83.5			
42205	100	16	5.0	83.5			

Nitrex as standard

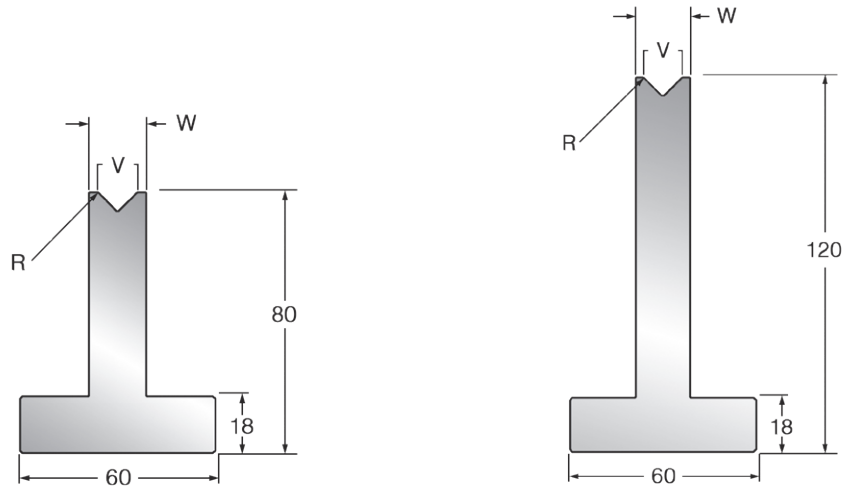

90° DIES								
CAT. NO.	V	R mm	W	H mm	ton/m	L	S	X
E40096	6	0.4	14	80	100			
E40098	8	0.5	14	80	80			
E40092	10	0.6	18	80	100			
E40094	12	0.8	18	80	80			
E40095	6	0.4	14	120	100			
E40097	8	0.5	14	120	80			
E40091	10	0.6	18	120	100			
E40093	12	0.8	18	120	80			

Induction hardened as standard

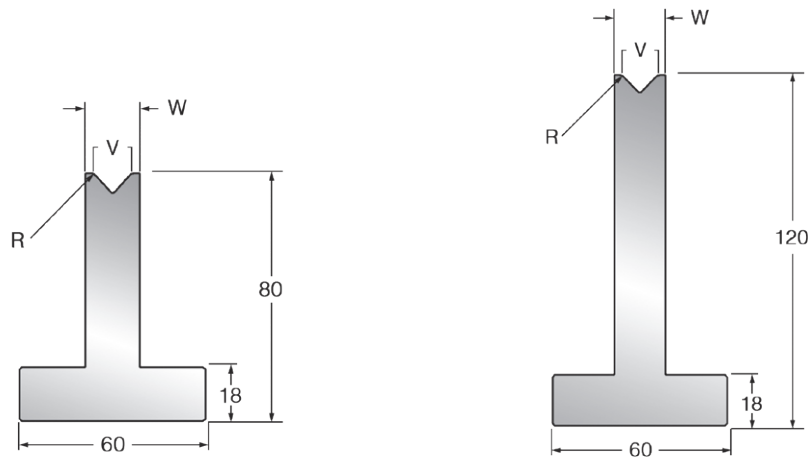

88° DIES								
CAT. NO.	V	R mm	W	H mm	ton/m	L	S	X
E40088	6	0.4	14	80	100			
E40090	8	0.5	14	80	80			
E40078	10	0.6	18	80	100			
E40080	12	2.75	18	80	80			
E40082	16	2.75	24	80	100			
E40084	20	3.0	30	80	100			
E40086	25	3.0	35	80	100			
E40087	6	0.4	14	120	100			
E40089	8	0.5	14	120	80			
E40077	10	0.6	18	120	100			
E40079	12	2.75	18	120	80			
E40081	16	2.75	24	120	100			
E40083	20	3.0	30	120	100			
E40085	25	3.0	35	120	100			

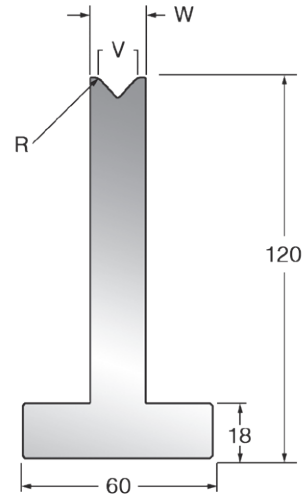
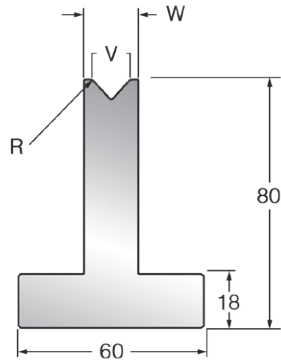

85° DIES								
CAT. NO.	V	R mm	W	H mm	ton/m	L	S	X
E40074	6	1.5	14	80	100			
E40076	8	1.5	14	80	80			
E40064	10	2.0	18	80	100			
E40066	12	2.75	18	80	80			
E40068	16	2.75	24	80	100			
E40070	20	3.0	30	80	100			
E40072	25	3.0	35	80	100			
E40073	6	1.5	14	120	100			
E40075	8	1.5	14	120	80			
E40063	10	2.0	18	120	100			
E40065	12	2.75	18	120	80			
E40067	16	2.75	24	120	100			
E40069	20	3.0	30	120	100			
E40071	25	3.0	35	120	100			

Induction hardened as standard

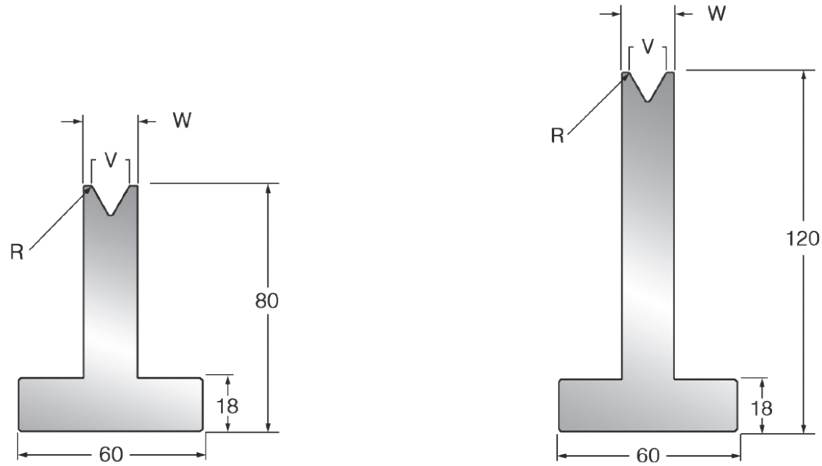

60° DIES								
CAT. NO.	V	R mm	W	H mm	ton/m	L	S	X
E40059	6	0.4	14	80	60			
E40062	8	0.5	14	80	60			
E40049	10	0.6	18	80	60			
E40051	12	0.8	18	80	60			
E40053	16	3.0	24	80	60			
E40055	20	3.0	30	80	60			
E40057	25	3.0	35	80	60			
E40058	6	0.4	14	120	60			
E40061	8	0.5	14	120	60			
E40048	10	0.6	18	120	60			
E40050	12	0.8	18	120	60			
E40052	16	3.0	24	120	60			
E40054	20	3.0	30	120	60			
E40056	25	3.0	35	120	60			

Induction hardened as standard

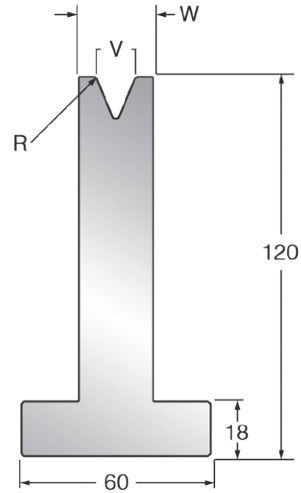
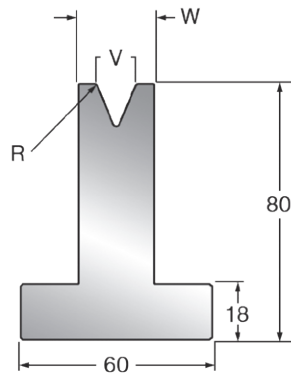

45° DIES								
CAT. NO.	V	R mm	W	H mm	ton/m	L	S	X
E40045	6	0.6	14	80	50			
E40047	8	0.8	18	80	50			
E40035	10	1.0	18	80	50			
E40037	12	1.5	24	80	50			
E40039	16	2.0	24	80	50			
E40041	20	2.5	30	80	50			
E40043	25	3.0	35	80	50			
E40044	6	0.6	14	120	50			
E40046	8	0.8	18	120	50			
E40034	10	1.0	18	120	50			
E40036	12	1.5	24	120	50			
E40038	16	2.0	24	120	50			
E40040	20	2.5	30	120	50			
E40042	25	3.0	35	120	50			

Induction hardened as standard

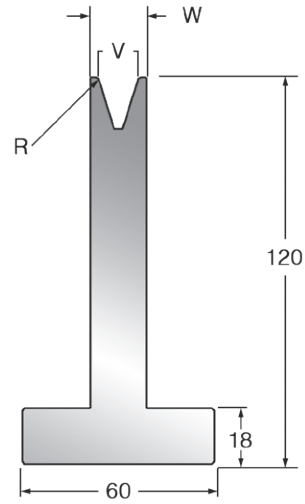
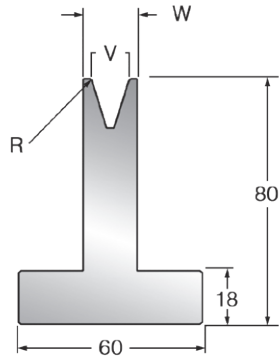

35° DIES								
CAT. NO.	V	R mm	W	H mm	ton/m	L	S	X
E40031	6	0.6	14	80	35			
E40033	8	0.8	14	80	35			
E40019	10	1.0	18	80	40			
E40021	12	1.5	18	80	40			
E40024	16	2.0	30	80	45			
E40026	20	2.5	35	80	50			
E40028	25	3.0	40	80	50			
E40029	6	0.6	14	120	35			
E40032	8	0.8	14	120	35			
E40018	10	1.0	18	120	40			
E40020	12	1.5	18	120	40			
E40022	16	2.0	30	120	45			
E40025	20	2.5	35	120	50			
E40027	25	3.0	40	120	50			

Induction hardened as standard

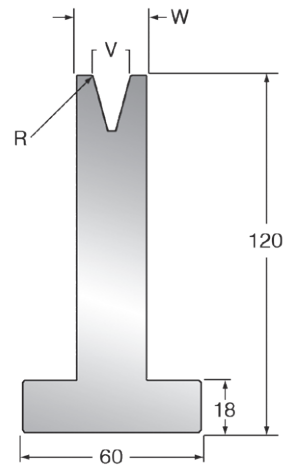
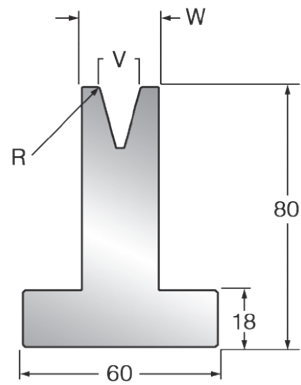

30° DIES								
CAT. NO.	V	R	W	H mm	ton/m	L	S	X
E40014	6	0.6	14	80	35			
E40017	8	0.8	18	80	35			
E40001	10	1.0	24	80	40			
E40004	12	1.5	24	80	40			
E40007	16	2.0	30	80	45			
E40010	20	2.5	35	80	50			
E40012	25	3.0	40	80	50			
E40013	6	0.6	14	120	35			
E40016	8	0.8	18	120	35			
E40000	10	1.0	24	120	50			
E40003	12	1.5	24	120	40			
E40005	16	2.0	30	120	45			
E40009	20	2.5	35	120	50			
E40011	25	3.0	40	120	50			

Induction hardened as standard

Cat. No. E42000

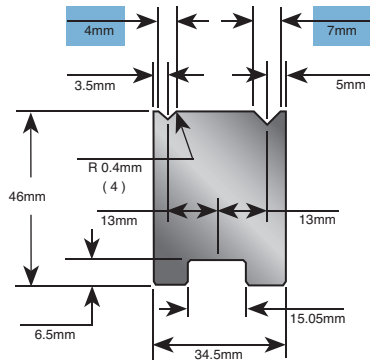

Cat. No. E42001

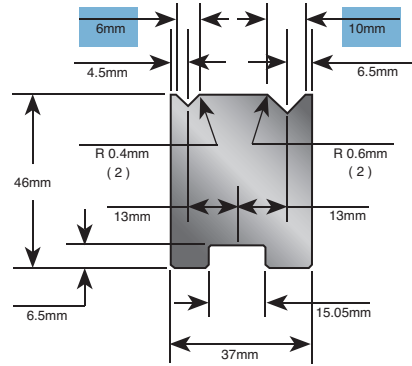

Cat. No. E42002

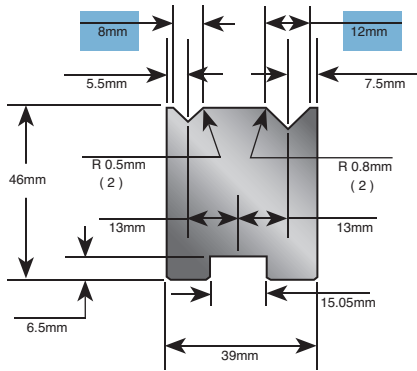

Cat. No. E42003

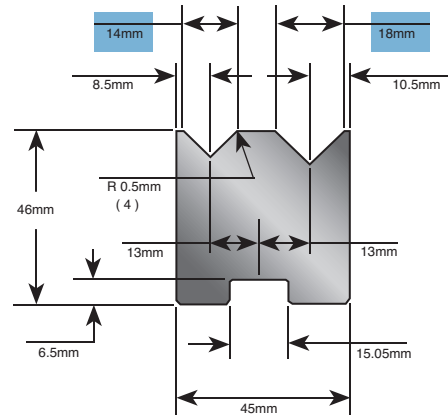

Cat. No. E42010

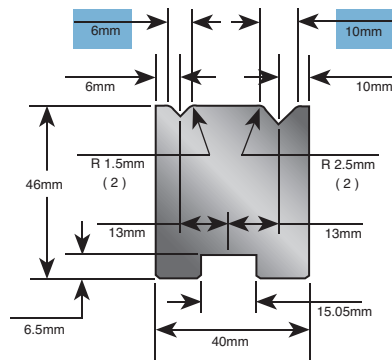

90° 2V DIES QC									
CAT. NO.	MAX. TON PER METRE	V1	V2	R1 mm	R2 mm	H mm	L 835 mm	S 415 mm	X 835 mm SECTIONALISED
E42000	60	4	7	0.4	0.4	46			
E42001	70	6	10	0.4	0.6	46			
E42002	80	8	12	0.5	0.8	46			
E42003	100	14	18	0.5	0.5	46			
LARGE RADII									
E42010	80	6	10	1.5	2.5	46			

Nitrex as standard

Cat. No. E42007

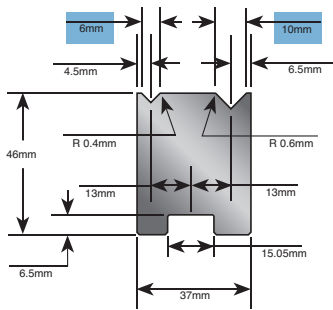

Cat. No. E42008

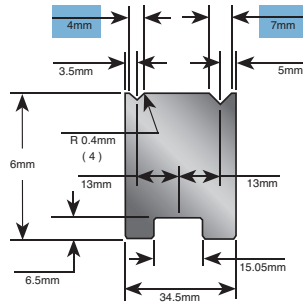

Cat. No. E42009

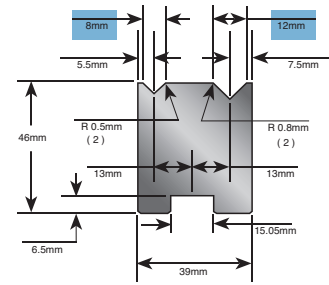

Cat. No. E42005

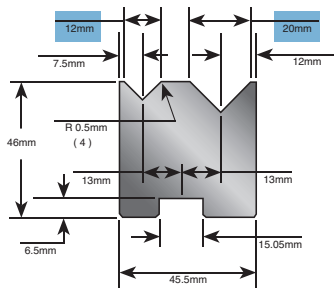

Cat. No. E42004

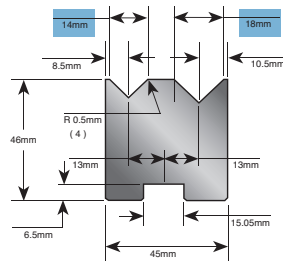

Cat. No. E42006

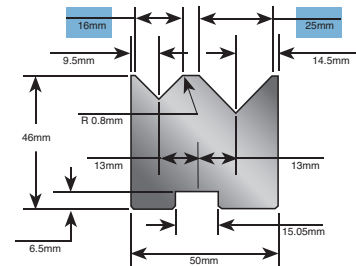

Cat. No. E42012

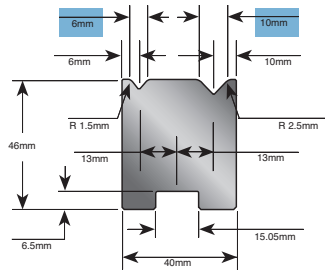

Cat. No. E42011

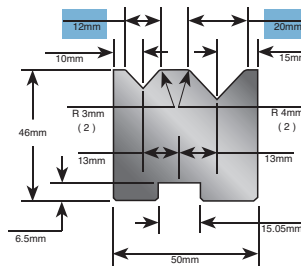

88° 2V DIES QC									
CAT. NO.	MAX. TON PER METRE	V1	V2	R1 mm	R2 mm	H mm	L 835 mm	S 415 mm	X 835 mm SECTIONALISED
E42007	60	6	10	0.4	0.6	46			
E42008	80	4	7	0.4	0.4	46			
E42009	70	8	12	0.5	0.8	46			
E42005	100	12	20	0.5	0.5	46			
E42004	100	14	18	0.5	0.5	46			
E42006	70	16	25	0.8	0.8	46			
LARGE RADII									
E42012	80	6	10	1.5	2.5	46			
E42011	100	12	20	3.0	4.0	46			

Nitrex as standard

Cat. No. E40099

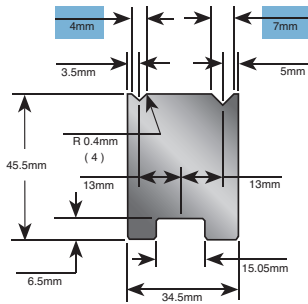

Cat. No. E40100

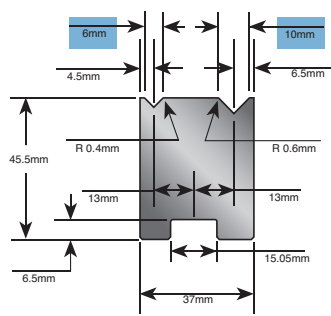

Cat. No. E40101

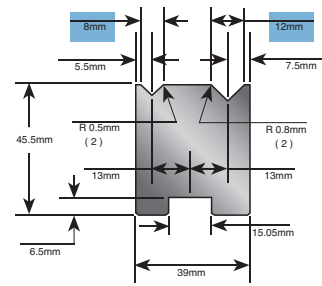

88° 2V DIES QC

CAT. NO.	MAX. TON PER METRE	V1	V2	R1 mm	R2 mm	H mm	L 835 mm	S 415 mm	X 835 mm SECTIONALISED
E40099	60	4	7	0.4	0.4	45.5			
E40100	70	6	10	0.4	0.6	45.5			
E40101	80	8	12	0.5	0.8	45.5			

Nitrex as standard

Cat. No. E42013

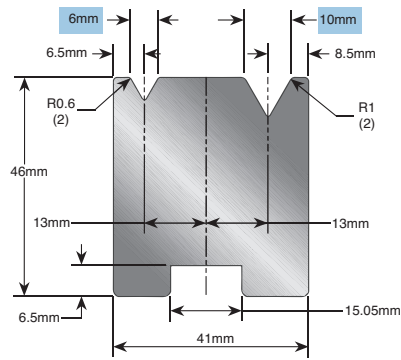

Cat. No. E42014

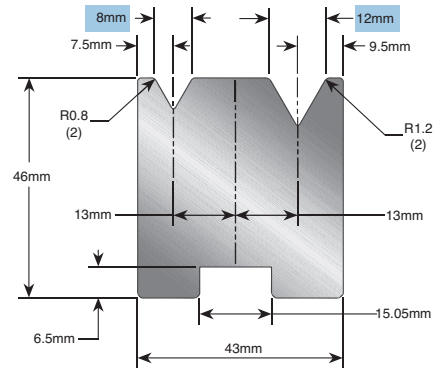

Cat. No. E42015

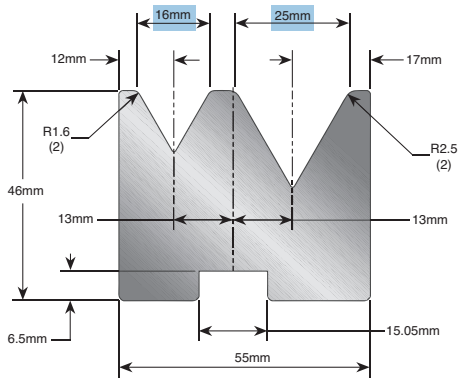

60° 2V DIES QC

CAT. NO.	MAX. TON PER METRE	V1	V2	R1 mm	R2 mm	H mm	L 835 mm	S 415 mm	X 835 mm SECTIONALISED
E42013	100	6	10	0.6	1.0	46			
E42014	100	8	12	0.8	1.2	46			
E42015	100	16	25	1.6	2.5	46			

Nitrex as standard

Cat. No. E42020

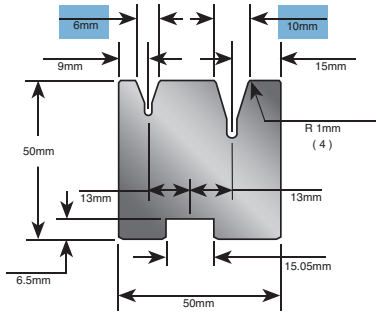

Cat. No. E42021

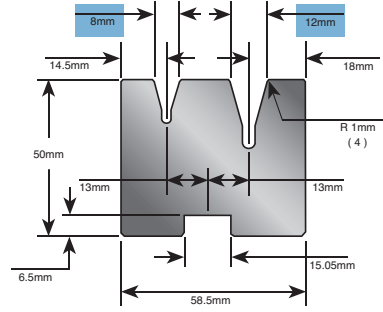

30° 2V DIES QC									
CAT. NO.	MAX. TON PER METRE	V1	V2	R1 mm	R2 mm	H mm	L 835 mm	S 415 mm	X 835 mm SECTIONALISED
E42020	30	6	10	1.0	1.0	50			
E42021	30	8	12	1.0	1.0	50			

Nitrex as standard

Cat. No. E42030

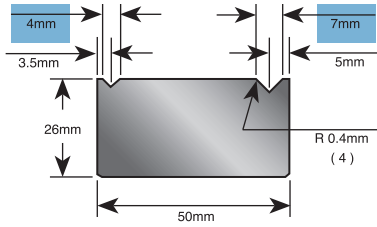

Cat. No. E42031

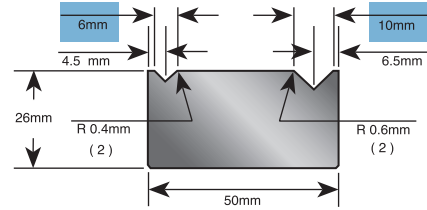

Cat. No. E42032

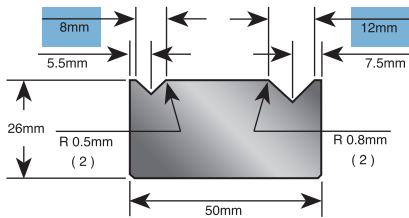

Cat. No. E42033

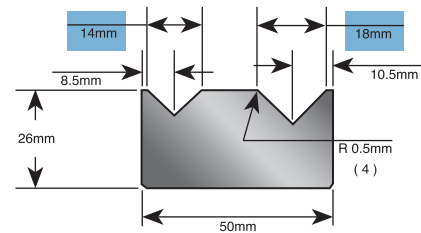

Cat. No. E42040

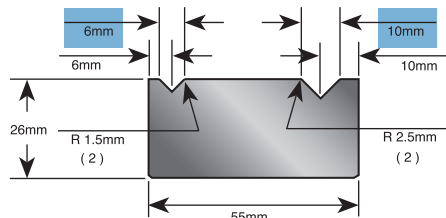

90° BOLT ON DIES								
CAT. NO.	MAX. TON PER METRE	V1	V2	R1 mm	R2 mm	H mm	L 835 mm	S 415 mm
E42030	60	4	7	0.4	0.4	26		
E42031	60	6	10	0.4	0.6	26		
E42032	80	8	12	0.5	0.8	26		
E42033	100	14	18	0.5	0.5	26		
LARGE SHOULDER RADII								
E42040	80	6	10	1.5	2.5	26		

Induction hardened as standard

Cat. No. E42037

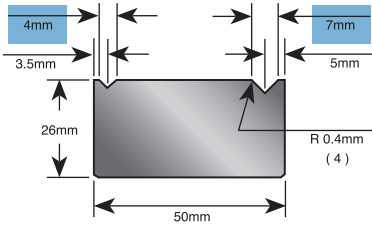

Cat. No. E42038

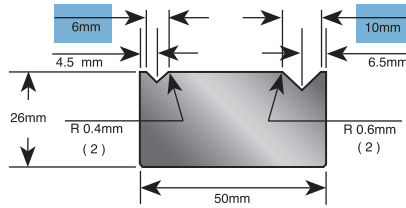

Cat. No. E42039

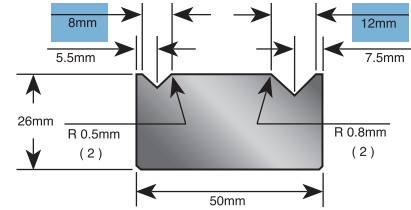

Cat. No. E42034

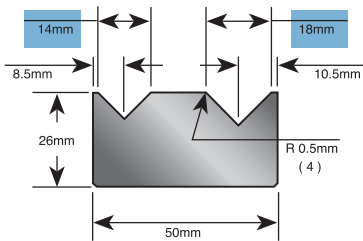

Cat. No. E42035

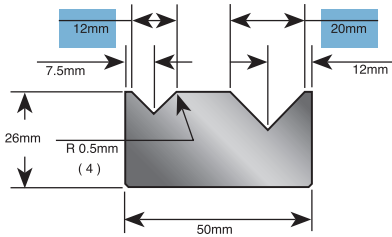

Cat. No. E42036

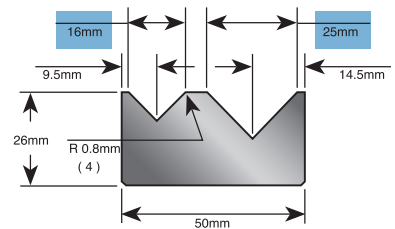

Cat. No. E42042

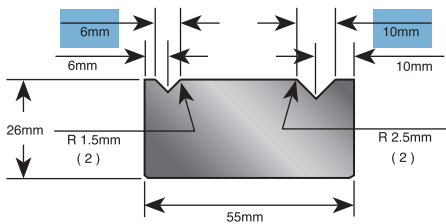

Cat. No. E42041

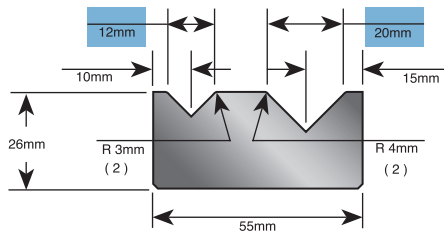

Cat. No. E42043

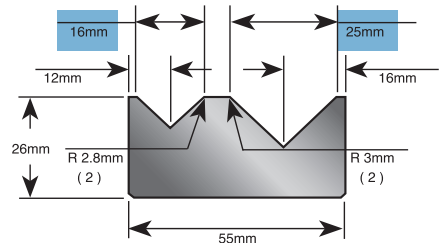

88° BOLT ON DIES

CAT. NO.	MAX. TON PER METRE	V1	V2	R1 mm	R2 mm	H mm	L 835 mm	S 415 mm
E42037	60	4	7	0.4	0.4	26		
E42038	70	6	10	0.4	0.6	26		
E42039	80	8	12	0.5	0.8	26		
E42034	100	14	18	0.5	0.5	26		
E42035	100	12	20	0.5	0.5	26		
E42036	100	16	25	0.8	0.8	26		

LARGE SHOULDER RADII

E42042	80	6	10	1.5	2.5	26		
E42041	80	12	20	3.0	4.0	26		
E42043	70	16	25	2.8	3.0	26		

Cat. No. E42044

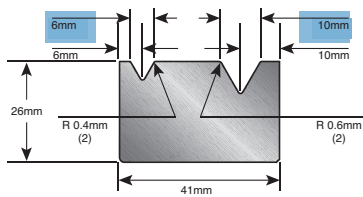

Cat. No. E42045

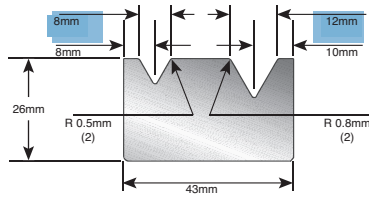

Cat. No. E42046

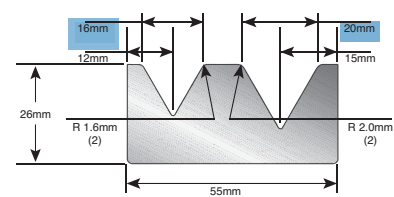

60° BOLT ON DIES								
CAT. NO.	MAX. TON PER METRE	V1	V2	R1 mm	R2 mm	H mm	L 835 mm	S 415 mm
E42044	60	6	10	0.4	0.6	26		
E42045	80	8	12	0.5	0.8	26		
E42046	20	16	20	1.6	2.0	26		

Induction hardened as standard

42341L & 42341S

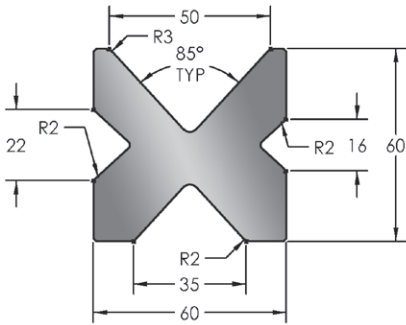

42340L & 42340S

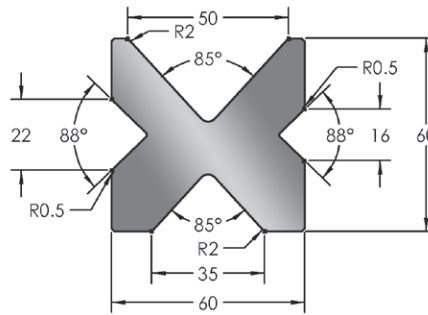

42342L & 42342S

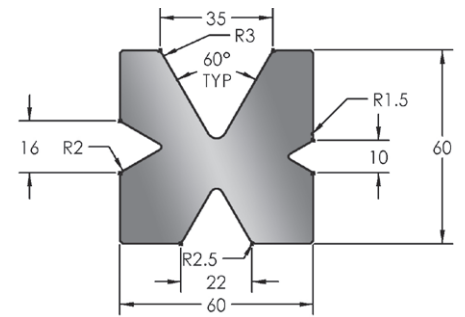

4V DIES			
CAT. NO.	DESCRIPTION	L 835 mm	S 415 mm
42340	4V die 88° V16 & V22 - 85° V35 & V50		
42341	4V die 85° V16, V22, V35, V50		
42342	4V die 60° V10, V16, V22, V35		

Induction hardened as standard

Cat. No. E42400

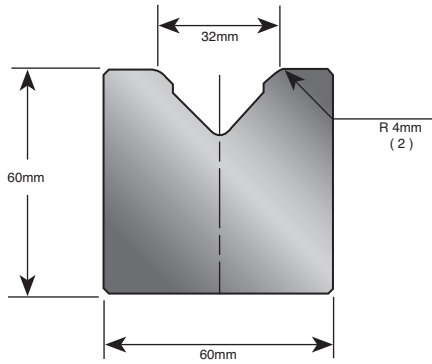

Cat. No. E42401

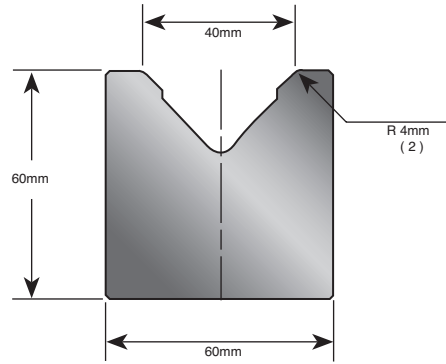

Cat. No. E42402

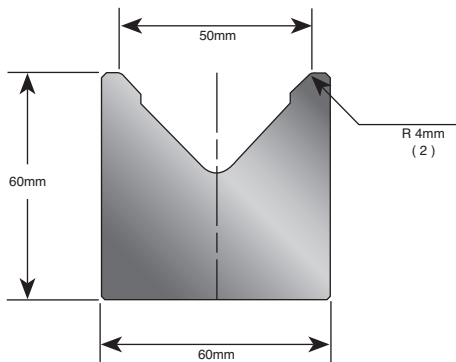

Cat. No. E42403

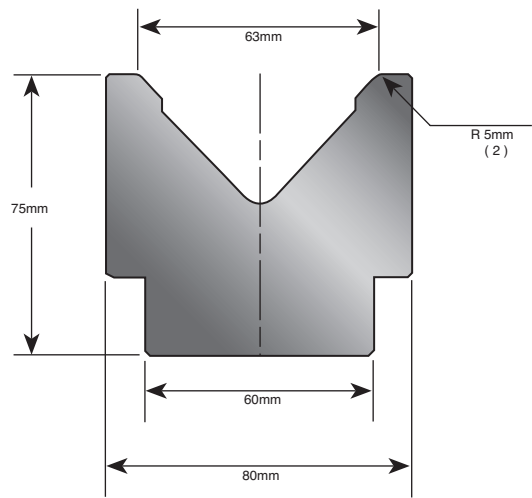

85° LARGE 1V DIES

CAT. NO.	MAX. TON PER METRE	V OPENING	W mm	H mm	R mm	L	S
						835 mm	415 mm
E42400	100	32	60	60	4		
E42401	100	40	60	60	4		
E42402	100	50	60	60	4		
E42403	100	63	80	75	5		

Induction hardened as standard

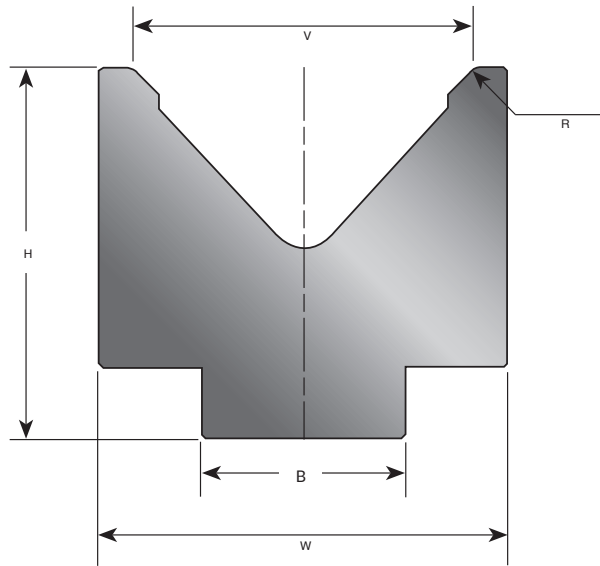

85° LARGE 1V DIES								
CAT. NO.	MAX. TON PER METRE	V OPENING	B	W mm	H mm	R mm	L 835 mm	S 415 mm
E42404	100	80	60	95	95	6		
E42405	100	100	60	120	110	7		

Induction hardened as standard

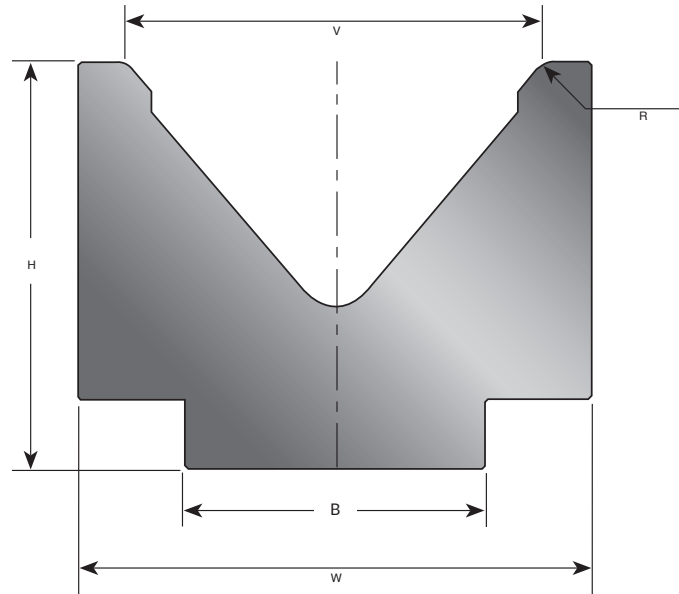

80° LARGE 1V DIES

CAT. NO.	MAX. TON PER METRE	V OPENING	B	W mm	H mm	R mm	L 835 mm	S 415 mm
E42408	100	100	60	125	110	7		
E42406	100	125	90	154	123	9		
E42407	100	160	90	185	130	11		

Induction hardened as standard

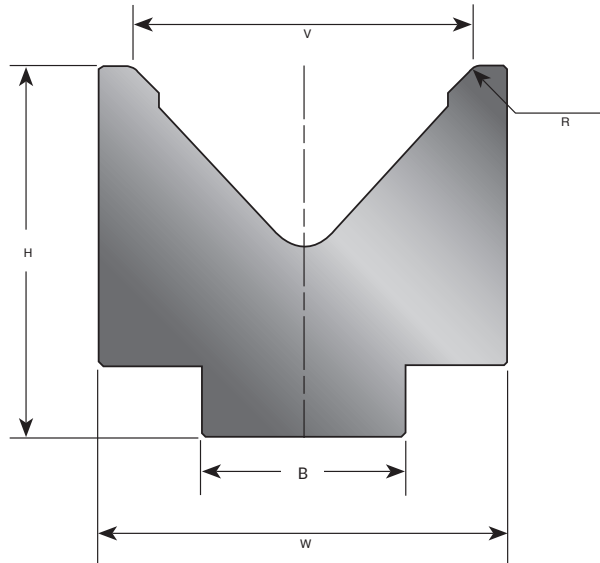

60° LARGE 1V DIE								
CAT. NO.	MAX. TON PER METRE	V OPENING	B	W mm	H mm	R mm	L 835 mm	S 415 mm
E42410	100	80	60	115	115	6		

Induction hardened as standard

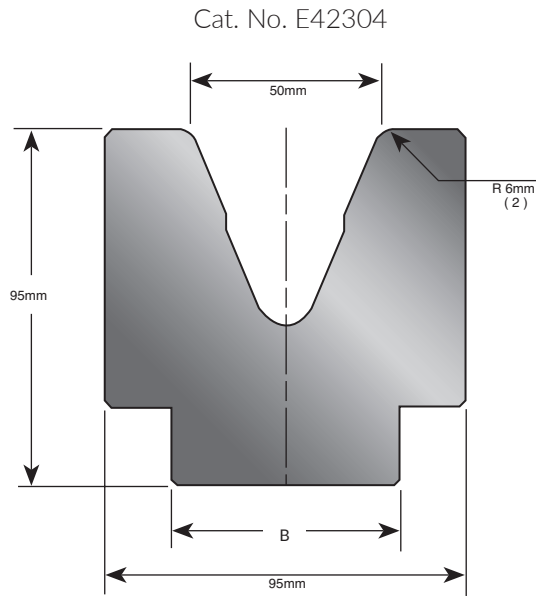
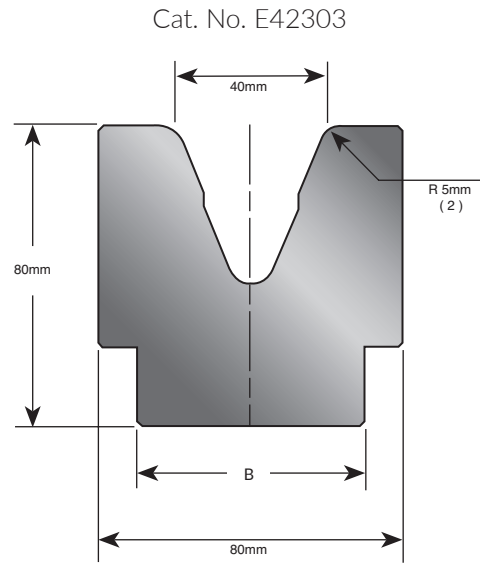
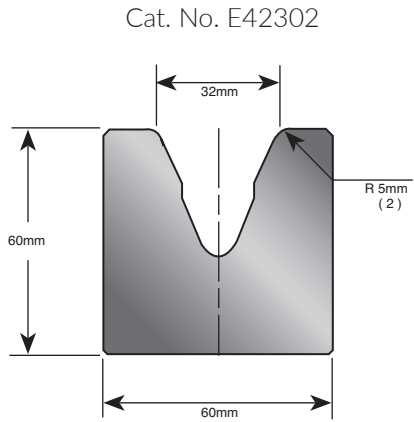

45° LARGE 1V DIES							
CAT. NO.	MAX. TON PER METRE	V OPENING	W mm	H mm	R mm	L 835 mm	S 415 mm
E42302	40	32	60	60	5.0		
E42303	70	40	80	80	5.0		
E42304	70	50	95	95	6.0		

Induction hardened as standard

Cat. No. E42300

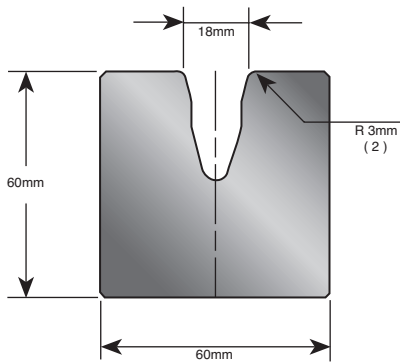

Cat. No. E42301

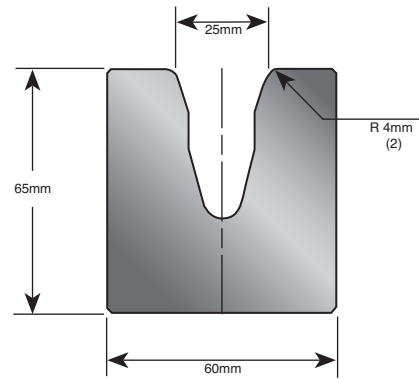

30° LARGE 1V DIES						
CAT. NO.	MAX. TON PER METRE	V OPENING	R mm	H mm	L 835 mm	S 415 mm
E42300	80	18	3.0	60		
E42301	60	25	4.0	65		

Induction hardened as standard

V-SERIES BLACK

Wilson Tool's V-Series Black press brake dies incorporate replaceable rotating inserts to decrease friction and to give better performance on certain tough-to-bend applications.

Manufactured by Wilson Tool, the Wilson V-Series Black is available for European, TRUMPF® and Wila style press brake tooling. The Wilson Tool V-Series Black die offers the following features:

- Higher quality tool steel
- Tighter tolerances
- Increased bend accuracy
- Shorter lead times

HARD-TO-BEND APPLICATION CAPABILITY

Wilson V-Series Black dies make it much easier to produce small flanges, small bend radii, bend close to holes and disappearing flanges. The Wilson V-Series Black also enables you to bend a wide range of materials using the same die, reducing set-up time and the number of dies you need to hold in stock.

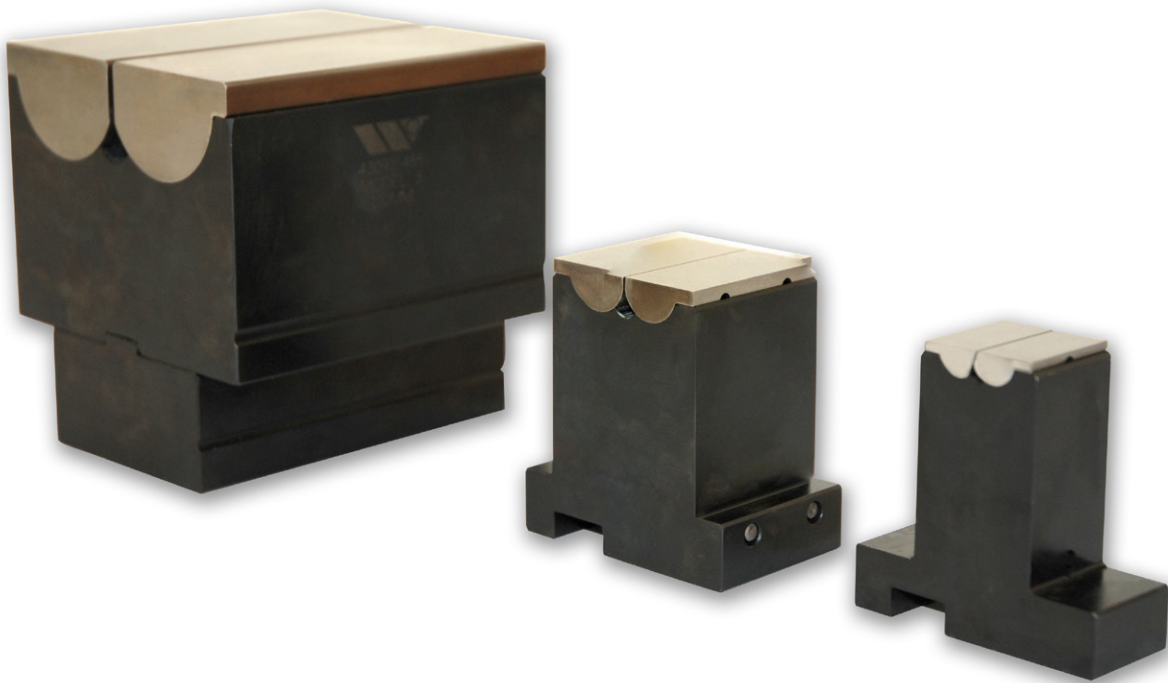

MODEL 1

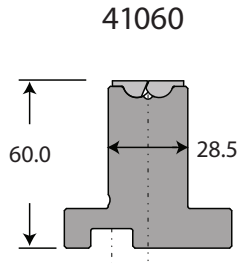

MODEL 2

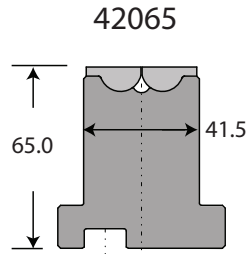

MODEL 3

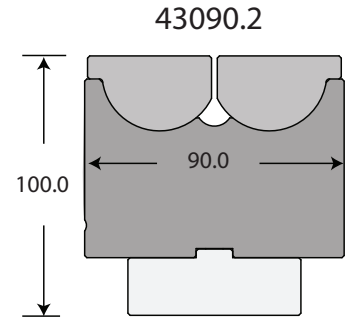

	MATERIAL THICKNESS	MIN. OUTSIDE FLANGE	T/M*	MIN. ANGLE	PUNCH TIP REQUIRED TO ACHIEVE ANGLE	MAX OR @ MIN. ANGLE	MAX OR @ 90°	MAX T/M	MAX kN/M
MODEL 1	0.45 mm	3.0 mm	5.9	34°	1.4	3.1 mm	4.45 mm	112	1100
	0.50 mm		5.9		1.3				
	0.60 mm		6.6		1.2				
	0.80 mm		8.2		1.1				
	0.90 mm		10.8		1.0				
	1.0 mm	3.9 mm	13.1	0.8					
	1.2 mm		19.0						
	1.5 mm		29.5						
MODEL 2	1.9 mm	8.5 mm	23.0	42°	3.0	5.5 mm	9.0 mm	168	1650
	2.9 mm	8.8 mm	42.7		2.8				
	3.0 mm	9.3 mm	49.2		2.5				
	3.2 mm		65.6	2.3					
	3.4 mm		72.2	55°	2.1				
MODEL 3	4.0 mm	22.5 mm	29.5	65°	2.0	11.5 mm	20.2 mm	204	2000
	4.75 mm		85.3		2.4				
	6.35 mm		91.9		3.2				

Please check to ensure the beam on your machine can withstand the tonnages shown above.
 *T/M calculations for Mild Steel only. 50% less for Aluminium, 50% more for the Stainless Steel

Inserts for Model 1 & 2: HRC 45
 Inserts for Model 3: HRC 58-60

Consume 60% of the insert when bending to prevent insert damage.

MODEL 1 & 2

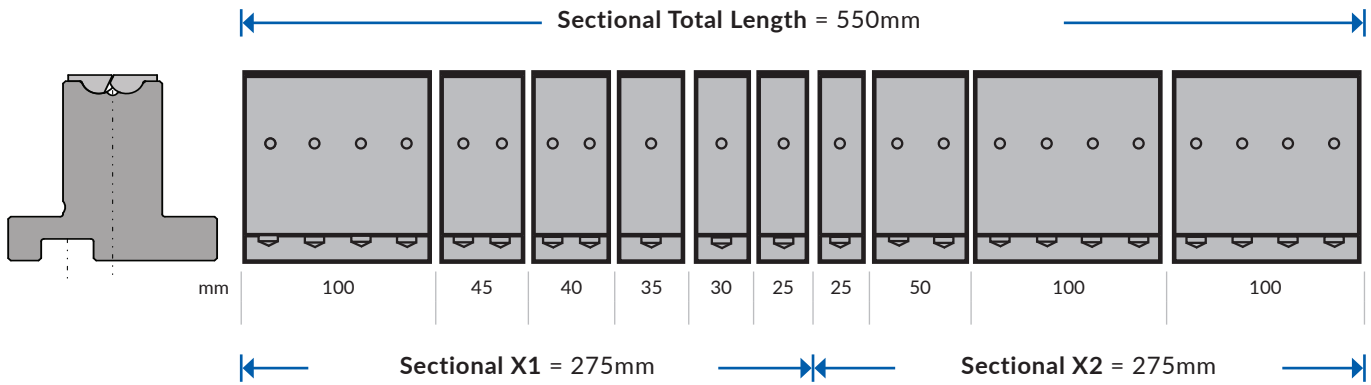

MODEL 3

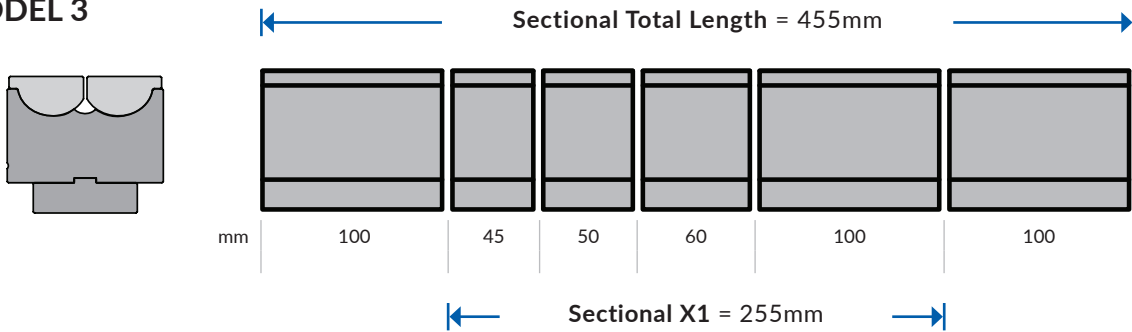

	CAT. NO.	DESCRIPTION	PRICE
MODELS 1 & 2	41060-500	500 mm Piece	
	41060-250	250 mm Piece	
	41060-550	550 Section	
	41060X1	Sectional X1 - Sets as above	
	41060X2	Sectional X2 - Sets as above	
	42065-500	500 mm Piece	
	42065-250	250 mm Piece	
	42065-550	550 Section	
	42065X1	Sectional X1 - Sets as above	
	42065X2	Sectional X2 - Sets as above	
MODEL 3	43090.2-100	100 mm Piece	
	43090.2-250	250 mm Piece	
	43090.2X1	Sectional X1 - Sets as above	
	43090.2-455	455 Section Set	

Cat No. 42601

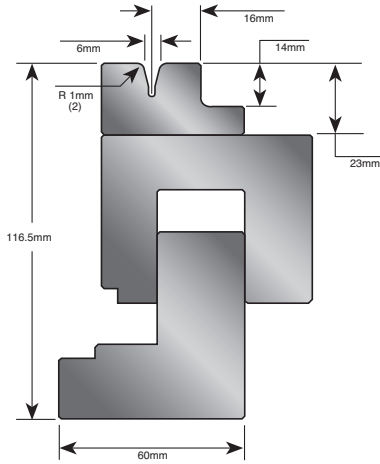

Cat No. 42602

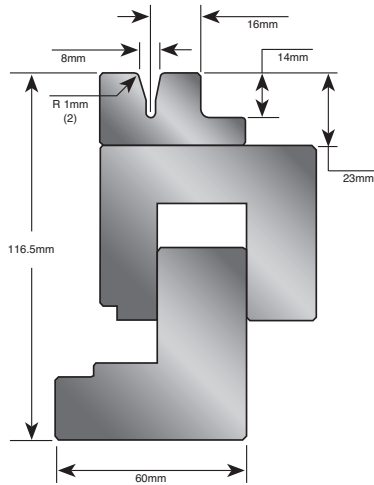

Cat No. 42603

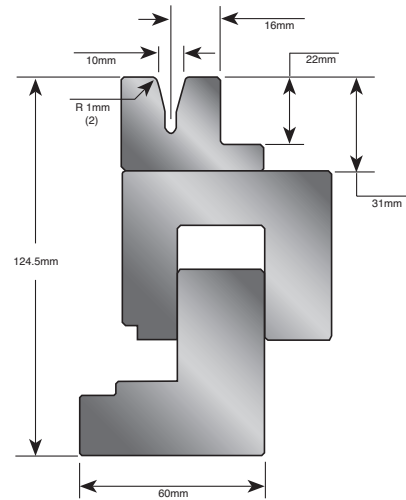

Replacement V-Blocks for Wilson Hemming Dies

Cat No. 42608

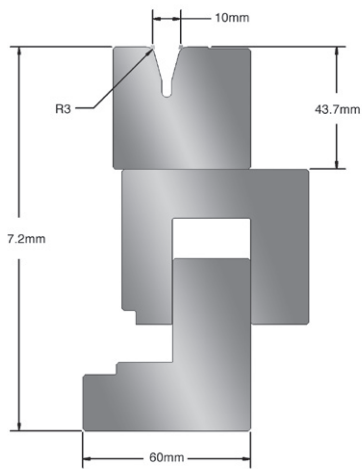

Cat No. 43522

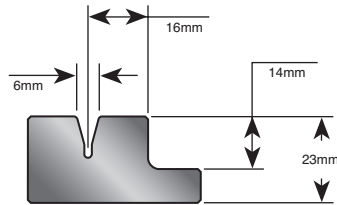

Cat No. 43523

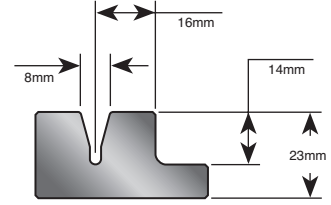

Cat No. 43524

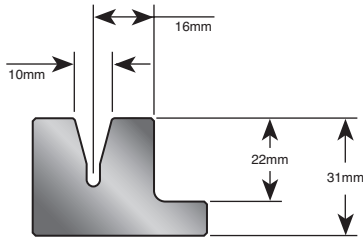

Cat No. 43528

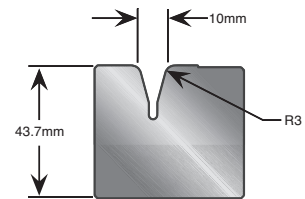

HEMMING DIES				
CAT. NO.	MAX. TON PER METRE	MAX MATERIAL C.R.S	LT 835 mm	ST 415 mm
42601	67	1.0 mm		
42602	67	1.2 mm		
42603	67	1.5 mm		
42608	67	2.0 mm		
43522	67	1.0 mm		
43523	67	1.2 mm		
43524	67	1.5 mm		
43528	82	2.0 mm		

Nitrex as standard

Cat No. E42630 & E42631

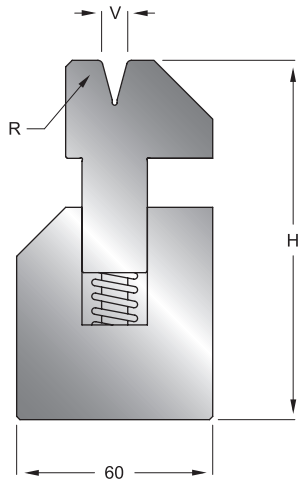

Cat No. E42632

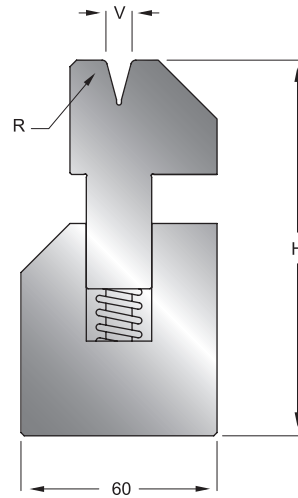

Cat No. E42633, E42634 & E42635

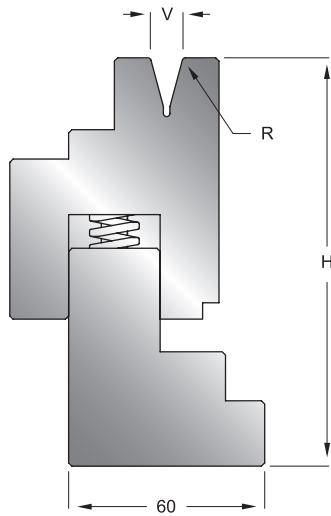

Cat No. E42636 & E42637

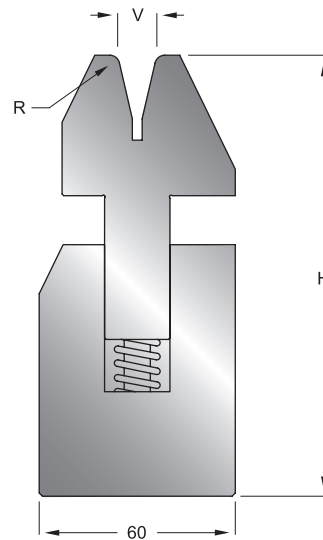

HEMMING DIES							
CAT. NO.	MAX. TON PER METRE	ANGLE	V OPENING	R mm	H mm	L 835 mm	S 415 mm
E42630	60	35°	6	1.0	105		
E42631	60	35°	8	2.0	105		
E42632	80	30°	8	1.5	110		
E42633	70	30°	6	1.0	117		
E42634	70	30°	8	1.0	117		
E42635	70	30°	10	1.0	135		
E42636	100	26°	10	1.5	135		
E42637	100	26°	12	3.0	135		

Induction hardened as standard

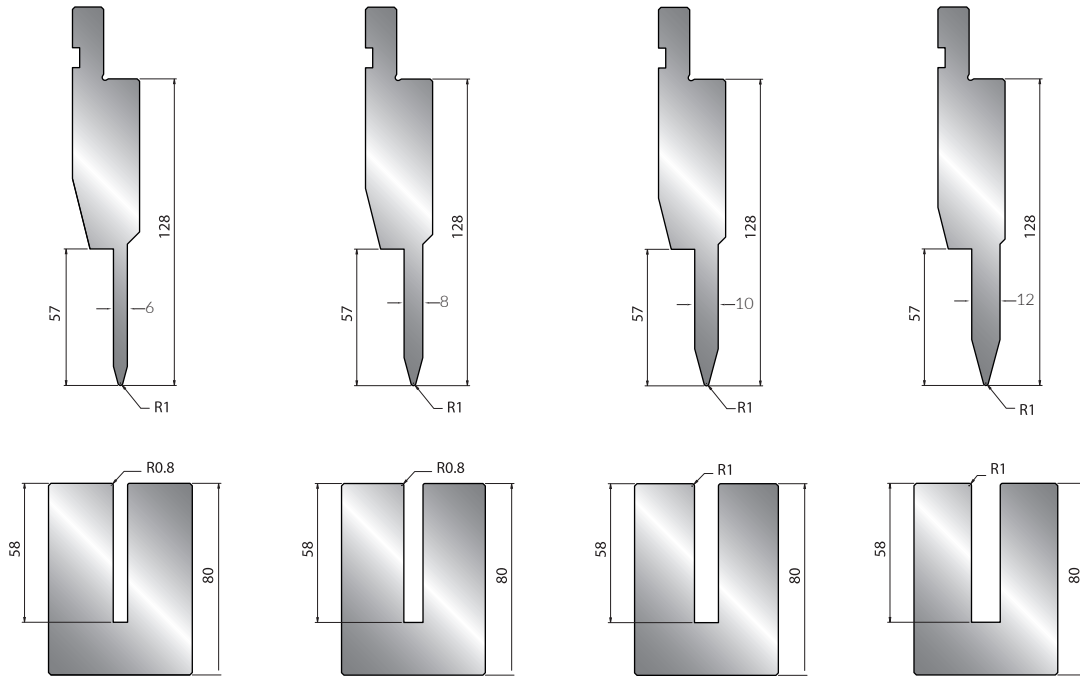

2 STAGE 30° HEMMING					
CAT. NO.	MAX BENDING TON/M	MAX FLATTENING TON/M	L 835 mm	S 415 mm	X 835 mm SECTIONALISED
E41920	50	80			
E41921	50	80			
E41922	50	80			
E41923	50	80			

Induction hardened as standard

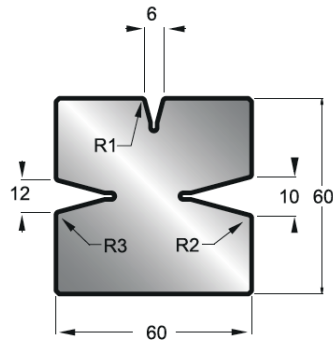

30° 3V HEMMING DIE							
CAT. NO.	MAX TON/M	R1 mm	R2 mm	R3 mm	L 835 mm	S 415 mm	X 835 mm SECTIONALISED
E42330	80	1.0	1.0	1.5			

Induction hardened as standard

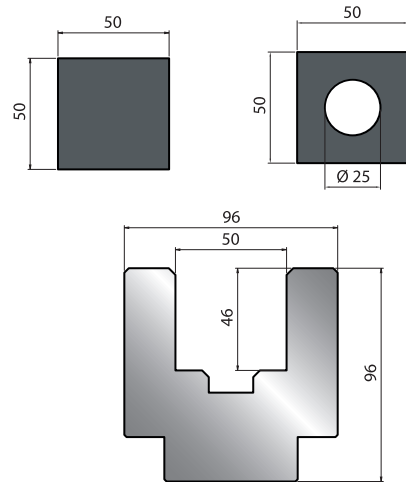
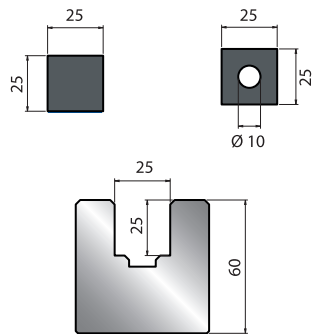

CAT. NO.	DESCRIPTION	PRICE	
		L	S
		835 mm	415 mm
E43160	Holder		
E43164	Pad without hole		
E43165	Pad with hole		

CAT. NO.	DESCRIPTION	PRICE	
		L	S
		835 mm	415 mm
E43161	Holder		
E43166	Pad without hole		
E43167	Pad with hole		

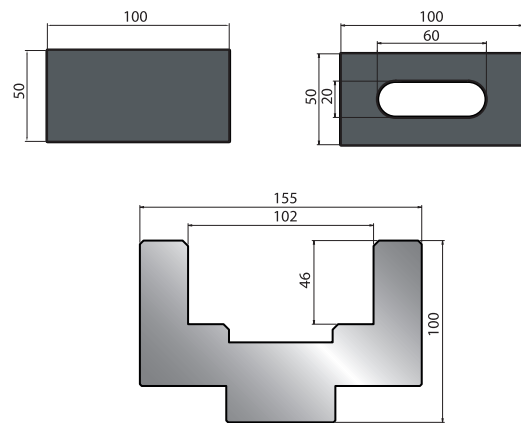
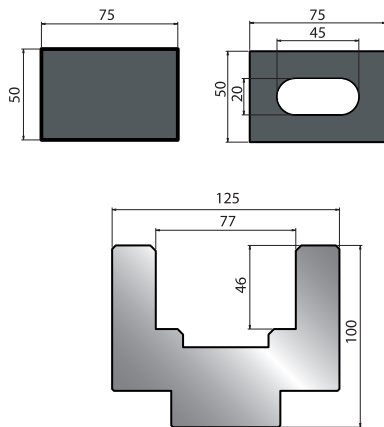

CAT. NO.	DESCRIPTION	PRICE	
		L	S
		835 mm	415 mm
E43162	Holder		
E43168	Pad without hole		
E43169	Pad with hole		

CAT. NO.	DESCRIPTION	PRICE	
		L	S
		835 mm	415 mm
E43163	Holder		
E43170	Pad without hole		
E43171	Pad with hole		

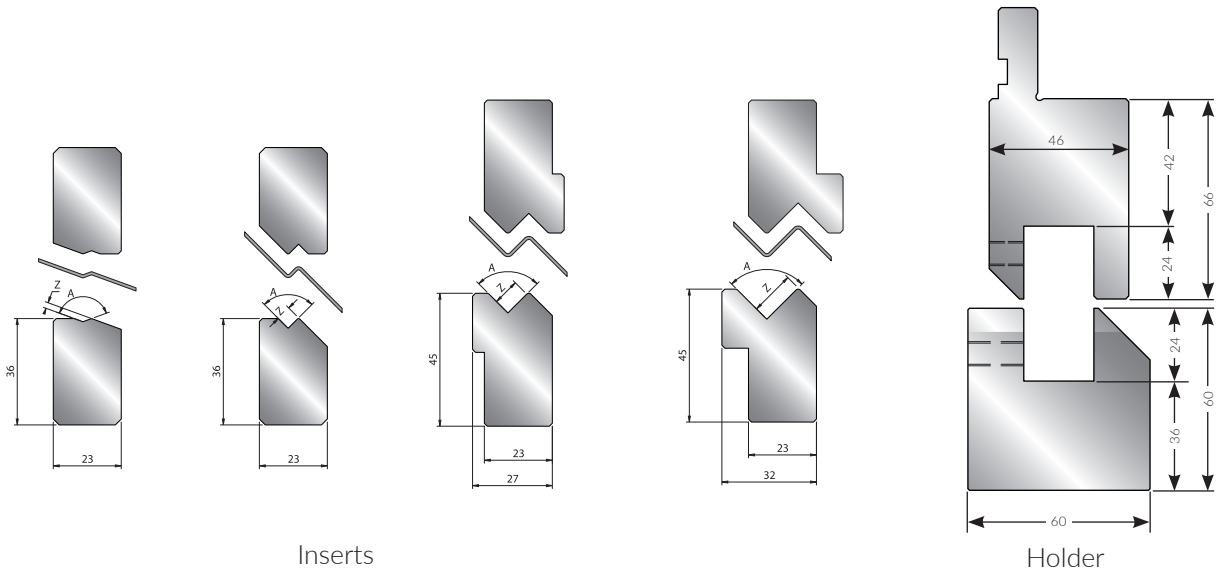

Inserts

Holder

CAT. NO.	Z (mm)	ANGLE	HH mm	MAX TON/M	L 835 mm	S 415 mm
E43131	1.0	160°	36	100		
E43132	1.5	160°	36	100		
E43133	2.0	150°	36	100		
E43134	2.5	140°	36	100		
E43135	1.0	90°	36	100		
E43136	1.5	90°	36	100		
E43137	2.0	90°	36	100		
E43138	2.5	90°	36	100		
E43139	3.0	90°	36	100		
E43140	3.5	90°	36	100		
E43141	4.0	90°	36	100		
E43142	4.5	90°	36	100		
E43143	5.0	90°	36	100		
E43144	5.5	90°	45	100		
E43145	6.0	90°	45	100		
E43146	6.5	90°	45	100		
E43147	7.0	90°	45	100		
E43148	7.5	90°	45	100		
E43149	8.0	90°	45	100		
E43150	9.0	90°	45	100		
E43151	10.0	90°	45	100		
E43152	11.0	90°	45	100		
E43153	12.0	90°	45	100		
E43154	13.0	90°	45	100		
E43155	14.0	90°	45	100		
E43156	15.0	90°	45	100		
CAT. NO.	DESCRIPTION			L 835 mm	S 415 mm	

E43130

Offset Tool Holder

Induction hardened as standard

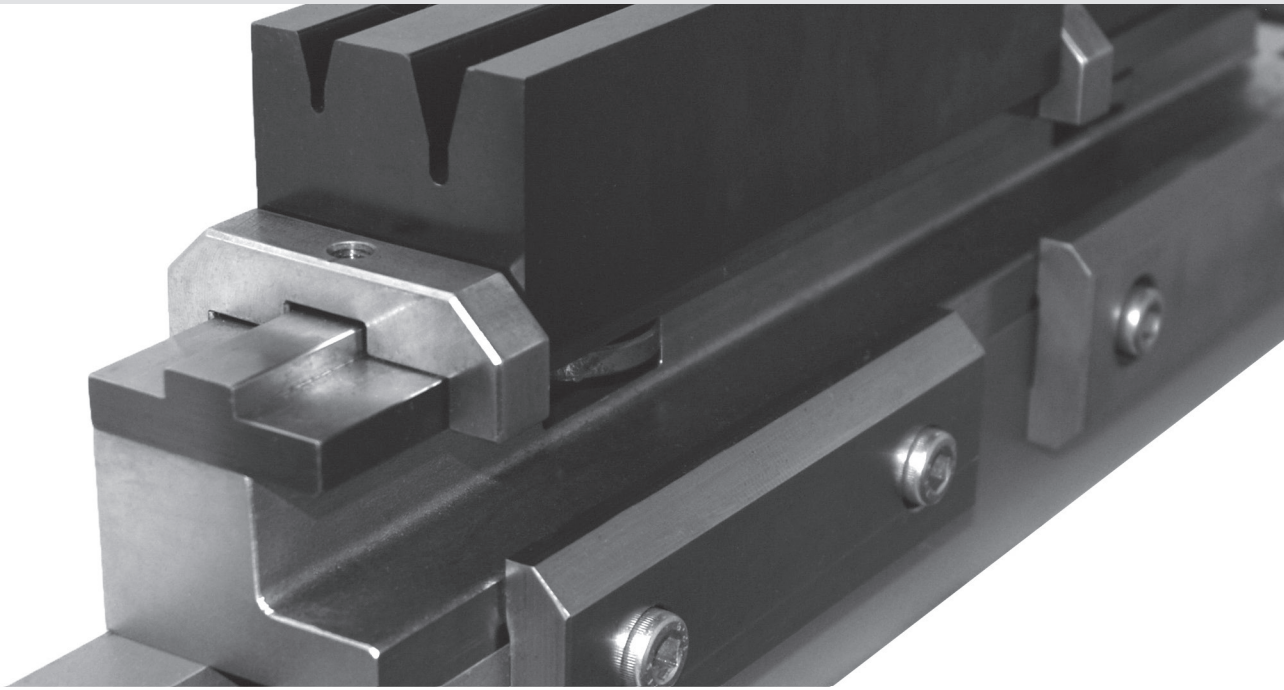

Holders and adapters hold dies in any style press brake. Holders offer extended height in the same tooling style and are available to convert from one style to another.

European Precision tooling is one of the most versatile press brake tool styles available, making it an operator favourite across the globe. Shorter punches are loaded into one or several segmented holders that increase overall height, affords the operator a lighter tool to handle and speeds set-ups. Two main die styles – quick-change 1V and quick-change 2V - provide alignment-free changeover and no need for an extra step to secure the die.

HOLDERS - WHICH ONE?

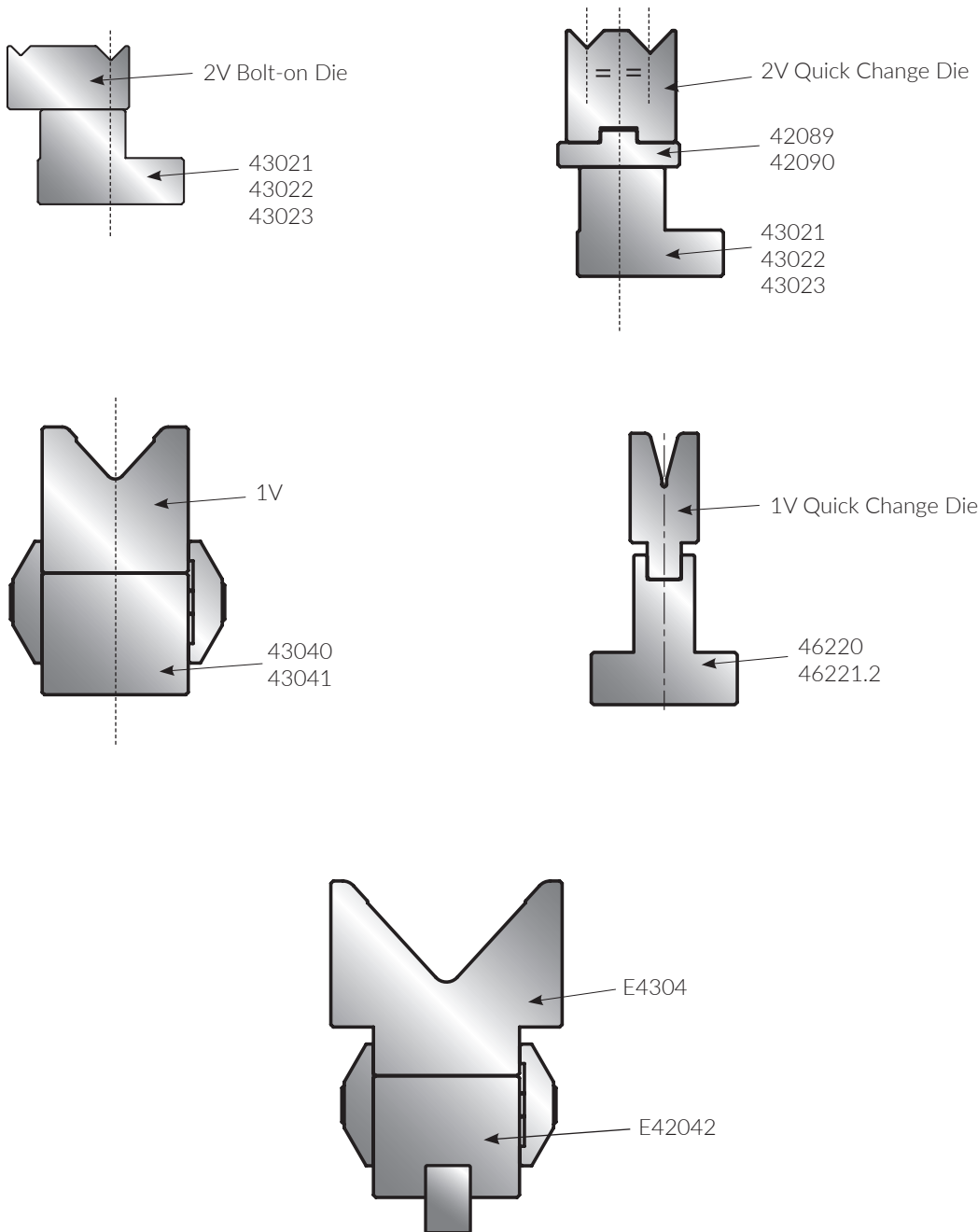

UNCLAMPED

Cat No. 46220

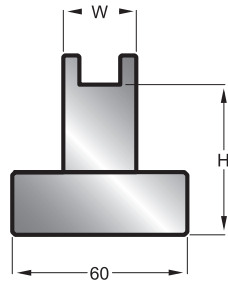

CLAMPED

Cat No. 46221.2

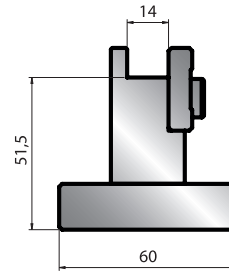

60 MM HIGH - QUICK CHANGE HOLDER				
CAT. NO.	MAX. TON PER METRE	H mm	L 835 mm	S 415 mm
46220	100	51.5		
CAT. NO.	MAX. TON PER METRE	H mm	L 840 mm	S 415 mm
46221.2	100	51.5		

Cat No. 43559



TOP VIEW



SIDE VIEW

WEDGE BLOCK ASSEMBLY	
CAT. NO.	PRICE
43559	

Cat No. 43030

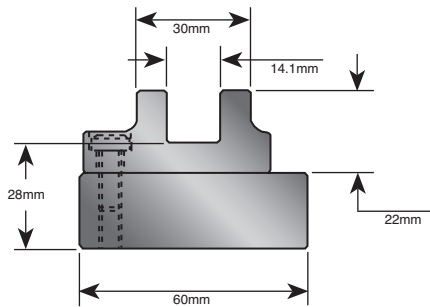

Cat No. 43530

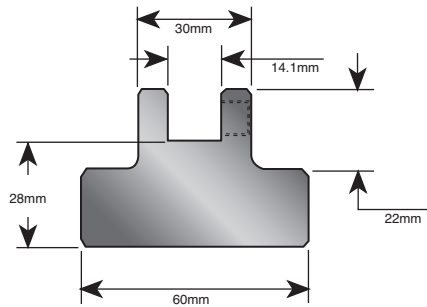

83.5 MM - QUICK CHANGE HOLDER		
CAT. NO.	L 835 mm	S 415 mm
43030		

83.5 MM - QUICK CHANGE HOLDER		
CAT. NO.	LT 835 mm	ST 415 mm
43530		

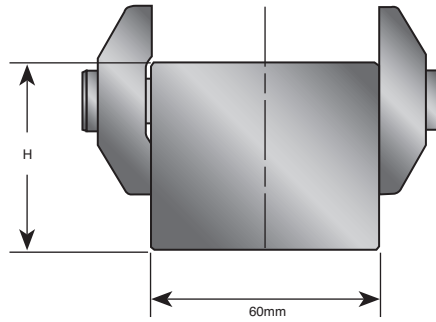

LARGE DIE HOLDER			
CAT. NO.	H mm	L 835 mm	S 415 mm
43040	50		
43041	55		

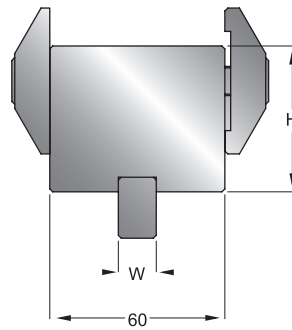

LARGE DIE HOLDER				
CAT. NO.	H mm	W mm	L 835 mm	S 415 mm
E43042	50	13.0		

Cat No. 43021

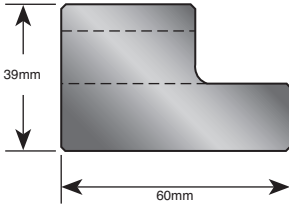

Cat No. 43022

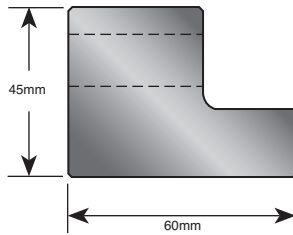

Cat No. 43023

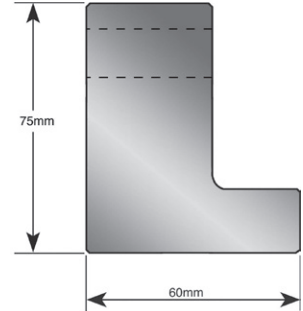

CAT. NO.	L 835 mm	S 415 mm
43021		
43022		
43023		

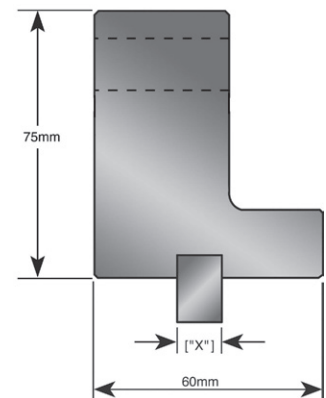
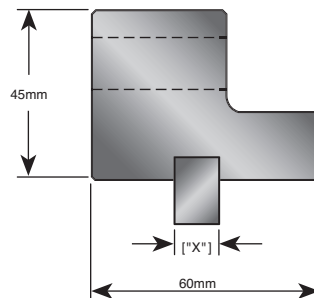
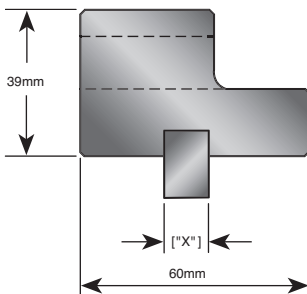

*Note: 2V die holders can be modified to convert your current press brake to use the 2V die system. Contact sales engineer or our sales desk.

Cat No. 42089/42090

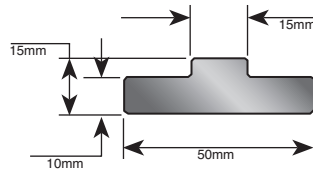

Cat No. 43553

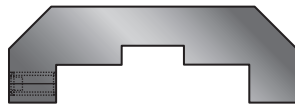

END VIEW



FRONT VIEW

DIE RAIL AND CLAMP				
CAT. NO.	DESCRIPTION	L 835 mm	S 415 mm	EACH
42090	Hardened 2V die rail	-	-	-
42089	2V die rail	-	-	-
43553	Rail Clamp Assembly	-	-	-

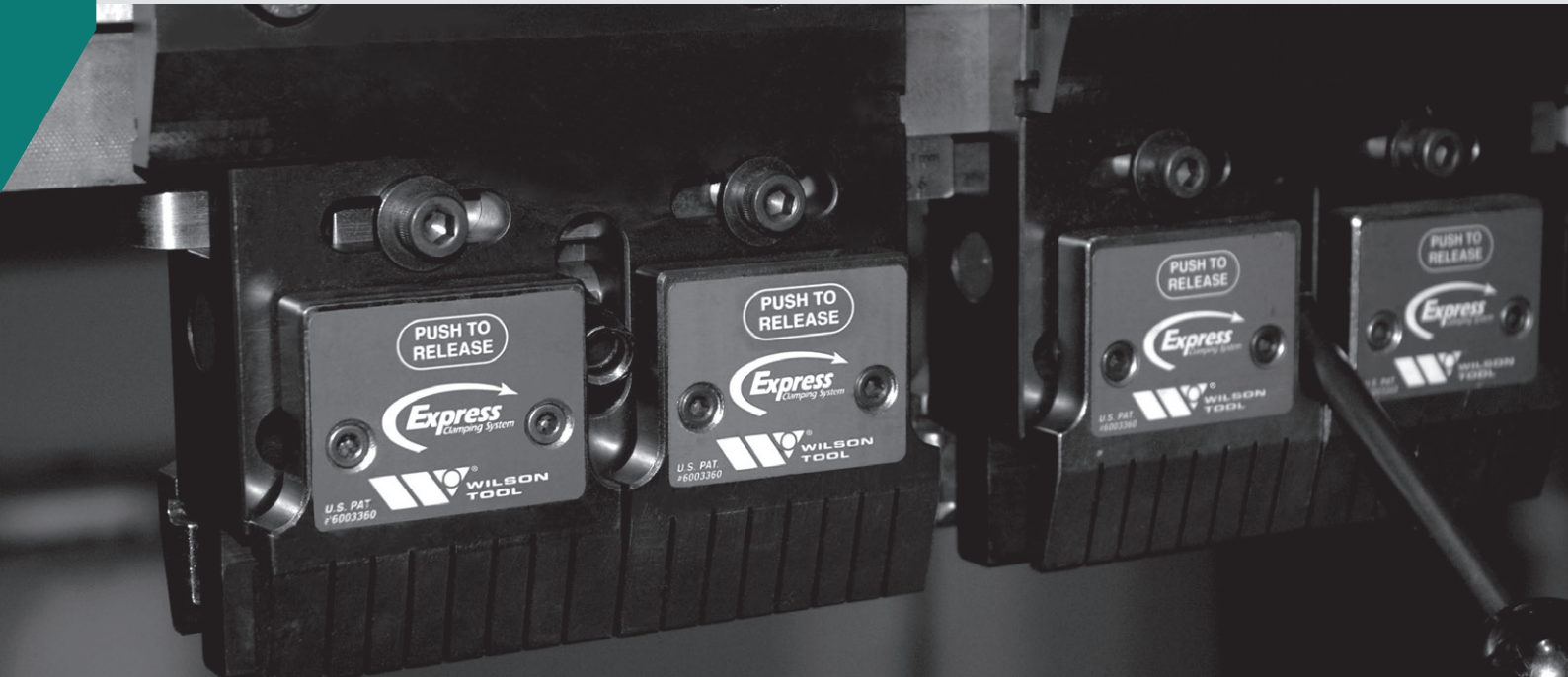

Basix

An economical clamping system for every day bending requirements. Available with a single clamp plate, this system is an effective option for those with long production runs, with infrequent set-ups.



Basix+

Our Basix+ clamping system is a great intermediate option for your clamping requirements. It is flexible with the option of both single and dual clamping. Interlocking and hardened body comes as standard. Each clamp wedge is lasered with a scale to help you instantly adjust for your individual bending needs.



Express

The Express Clamping system is available for virtually any make and model of press brake for Euro tooling, uniquely designed to increase your productivity and reduce operation costs. With the Express Clamp you can unload and load punches quickly and easily as it eliminates the need to slide punches to the end of the machine. A simple pull down locking lever unlocks the clamp allowing the operator to pull individual sections straight down, from any area of the press brake. This clamp is ideal for those who change tooling often and need a flexible clamp system to enhance productivity.



CLAMPING RECOMMENDATION BY APPLICATION	BASIX	BASIX+	EXPRESS
Single Clamp Plate	●	▲	★
Wedge Height Adjustment	●	▲	★
Available in Z1 & Z2 mounting options	●	▲	★
Dual Clamping Option		▲	★
Hardened Body		▲	★
Interlocking as Standard		▲	★
Laser scaled wedge as standard		▲	★
Vertical Loading			★
Quick Clamping			★
GOOD ● BETTER ▲ BEST ★			

Z1 Basix Clamp

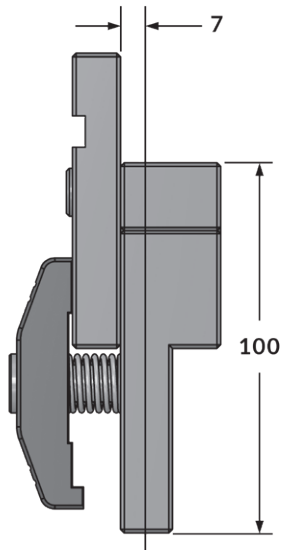

Z2 Basix Clamp

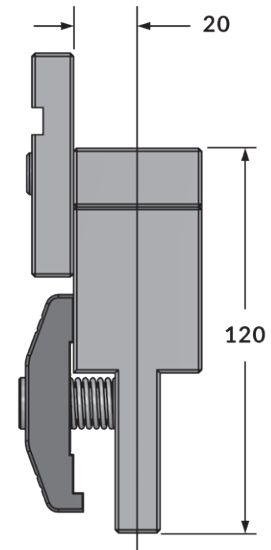

CAT. NO.	DESCRIPTION	PRICE
43920	Z1 Euro Basix Manual Single Clamp	
43925	Z2 Euro Basix Manual Single Clamp	

Z1 Basix+ Single Clamp

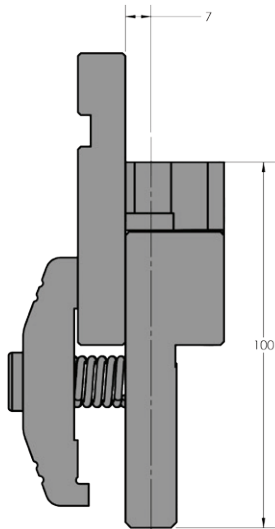

Z2 Basix+ Single Clamp

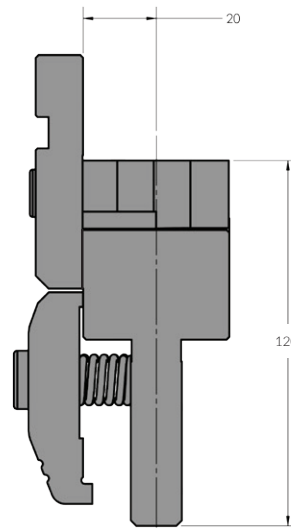

Z1 Basix+ Dual Clamp

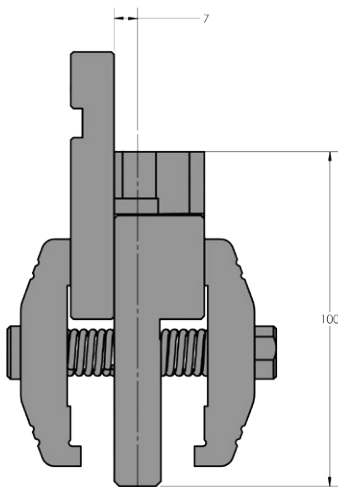

Z2 Basix+ Dual Clamp

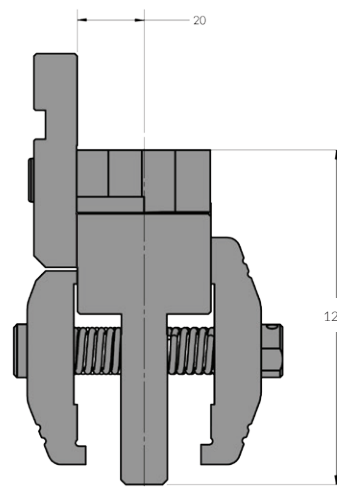

CAT. NO.	DESCRIPTION	PRICE
43930	Z1 Euro Basix+ Manual Single Clamp	
43935	Z2 Euro Basix+ Manual Single Clamp	
43938	Z1 Euro Basix+ Manual Dual Clamp	
43939	Z2 Euro Basix+ Manual Dual Clamp	

Z1 Express Clamp



Z2 Express Clamp



CAT. NO.	DESCRIPTION	H mm	PRICE
43817i	Z1 Series with Wedge, 4 Clamp Interlocking	100	
43817i-2	Z1 Series with Wedge, 2 Clamp Interlocking	100	
43818i	Z2 Series with Wedge, 4 Clamp Interlocking	120	
43818i-2	Z2 Series with Wedge, 2 Clamp Interlocking	120	
43821i	Z1 Series, Dual Plate with Wedge	150	
43821i-2	Z1 Series, Front Plate with Wedge	150	

Torque wrench sold separately, see Accessories section for details

TRUMPF® to Euro Express Clamp



CAT. NO.	DESCRIPTION	H mm	PRICE
43819	TRUMPF® to Euro Express Clamp	100	

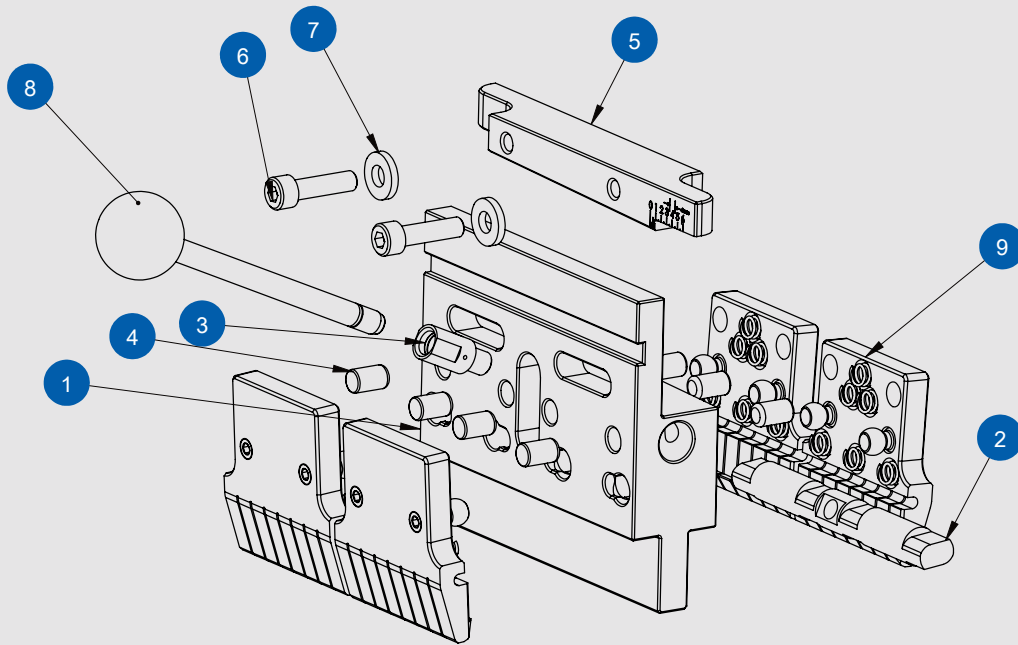

Z1 SERIES WITH WEDGE				
NO.	CAT. NO.	QTY	DESCRIPTION	PRICE
1	43811	1	Express Clamp Body	
2	43767	1	Express, Cam	
3	43727	1	Shaft Socket	
4	43705	8	Push Pin	
5	43766	1	Interlocking Wedge	
6	970508	2	Socket Head Cap Screw	
7	43709	2	Washer	
8	43020	1	Handle Assembly	
9	43812	4	Clamp Assembly	

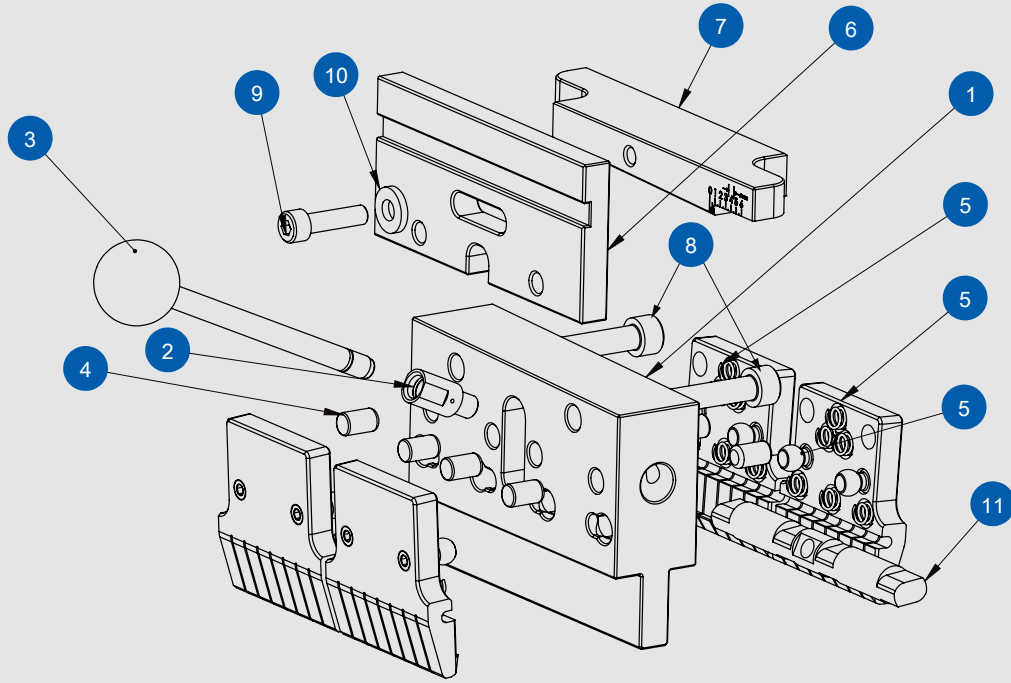

Z2 SERIES WITH WEDGE				
NO.	CAT. NO.	QTY	DESCRIPTION	PRICE
1	43838	1	Express Clamp Body	
2	43727	1	Shaft Socket	
3	43020	1	Handle Assembly	
4	43705	8	Push Pin	
5	43812	4	Clamp Assembly	
6	43736	1	Safety Clamp	
7	43765	1	Interlocking Wedge	
8	8002123	2	M10-1.5 x 40mm Socket Head Cap Screw	
9	970508	1	M8 x 30mm Socket Head Cap Screw	
10	43709	1	Washer	
11	43767	1	Express, Cam	

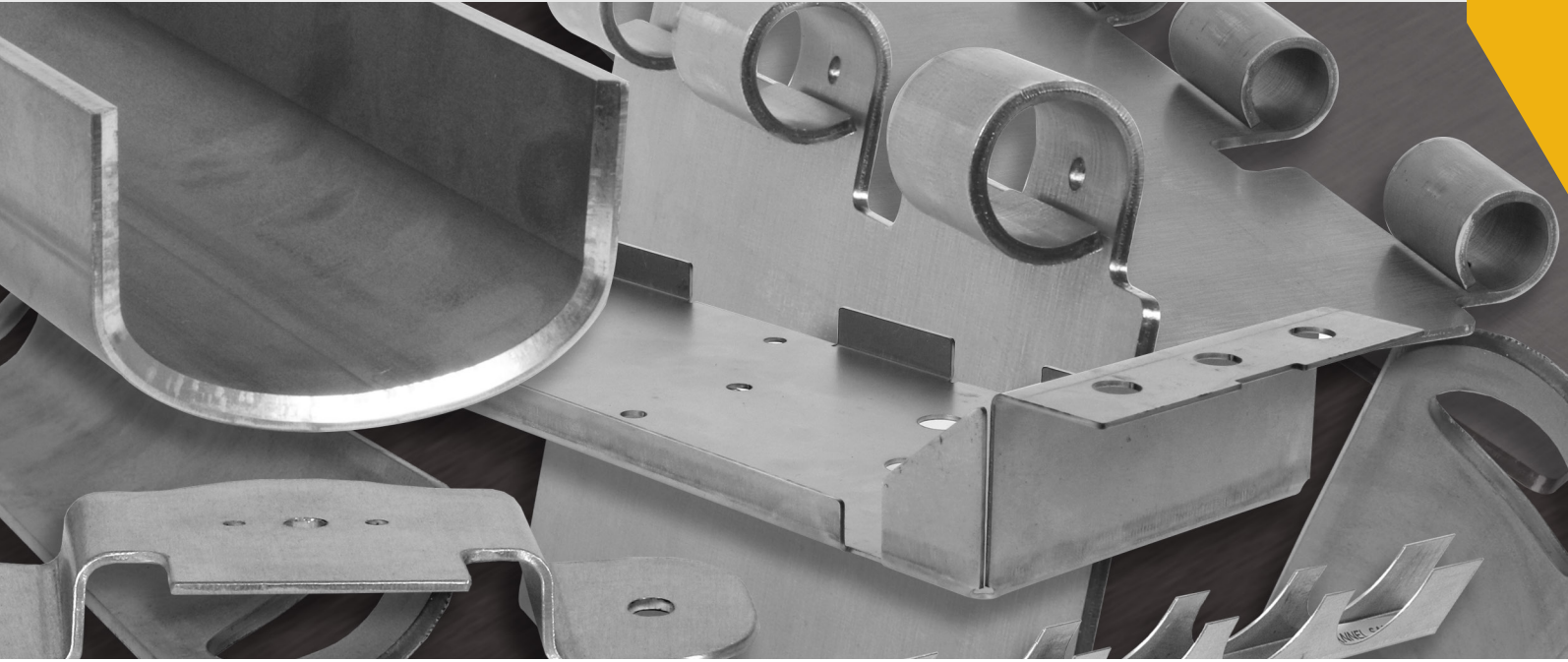

CHALLENGE US!

OUR “NEVER SAY NO” ATTITUDE

We regularly help customers with their most challenging applications. Our innovative solutions simplify complex bends and make the impossible possible. We are defined by our ‘never say no’ attitude. Bring us your most complex problem and we will work with you until we’ve found an effective solution.

QUALITY MATERIALS. QUALITY CONTROL.

We combine premium materials with specialized manufacturing systems to produce extraordinary products that outlast the competition.

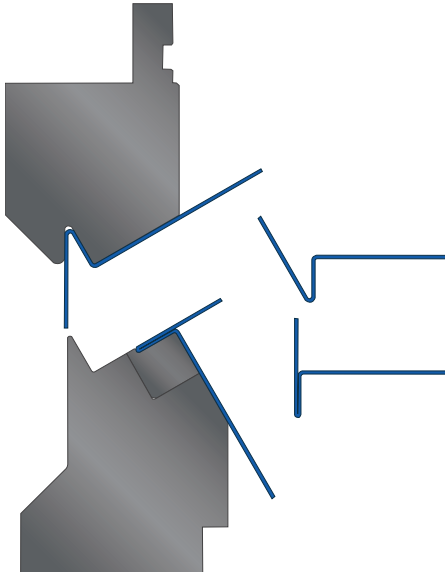

AH1 ANGLE HEM

Typically used to form seams in excess of 12mm.

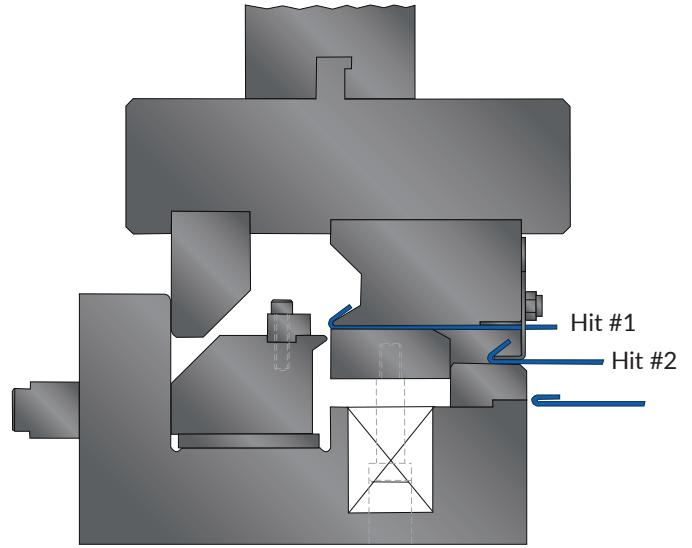

FSH1 FLAT SHEET HEM



HDH1 HEAVY DUTY HEM

Heavy Duty Hemming for thick gauge applications.

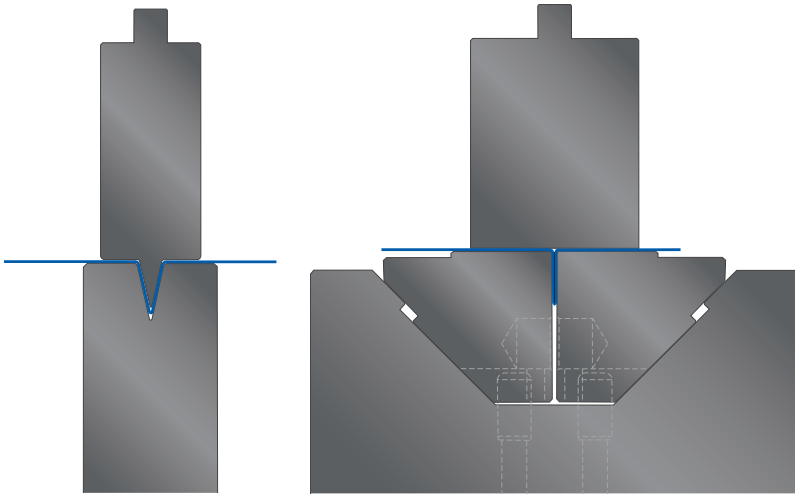

SH1 SEAM HEM

Two tool sets.
Two machine strokes.

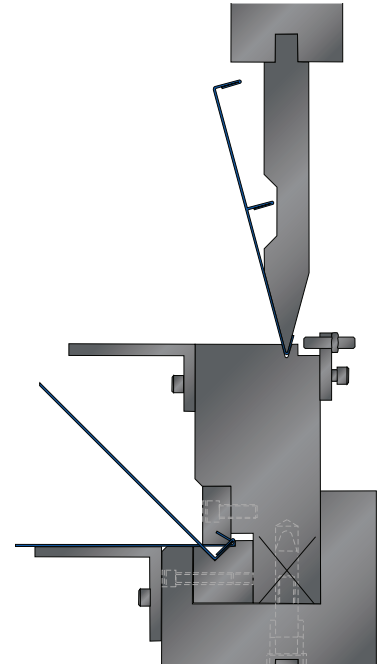

SSH2 STANDING SEAM HEM



See this tool in action on the
[Wilson Tool YouTube Channel](#)

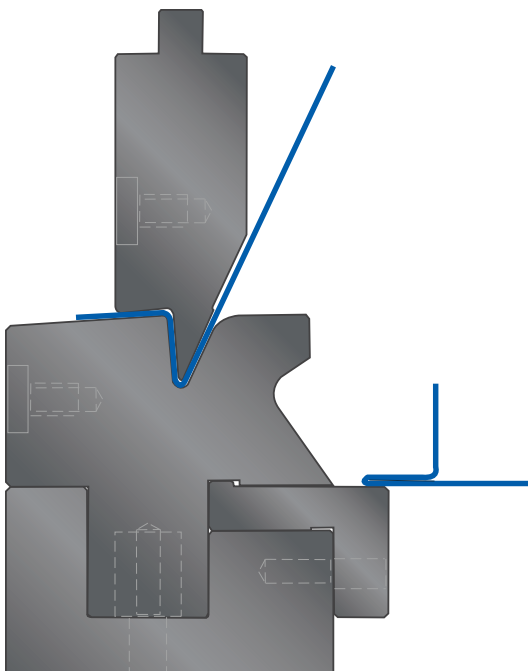

SSH1 STANDING SEAM HEM

Used to form a standing seam in 2 strokes.
The first stroke forms an acute angle
offset, the second stroke closes the seam.

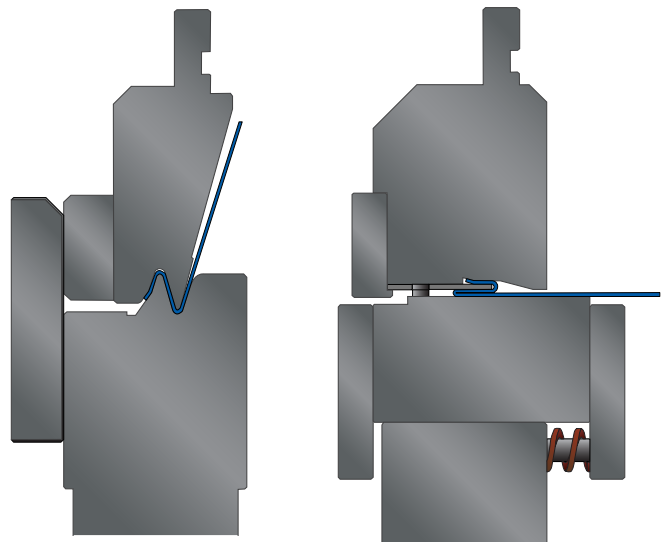

ZH1 Z HEM

Creates a Z-hem or a Clip hem.
Shim can be built in to maintain a gap in the
hem.
Two tool sets.
Two machine strokes.

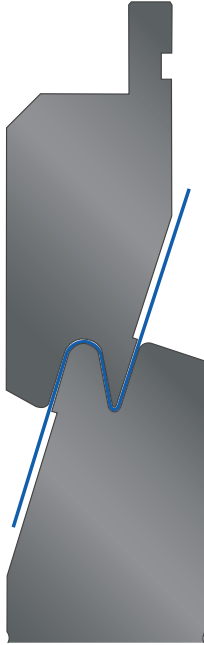

AO1 ANGLED OFFSET

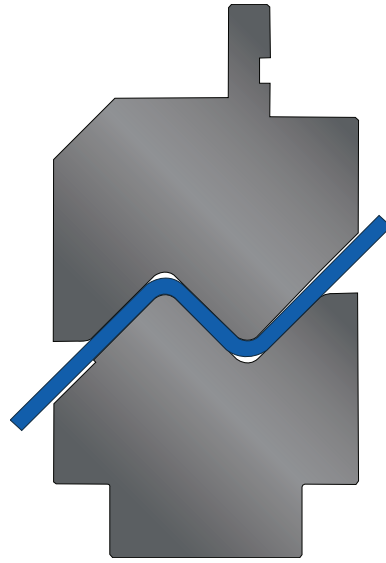

LO1 LARGE OFFSET

Used for heavy gauge, large offset bending.

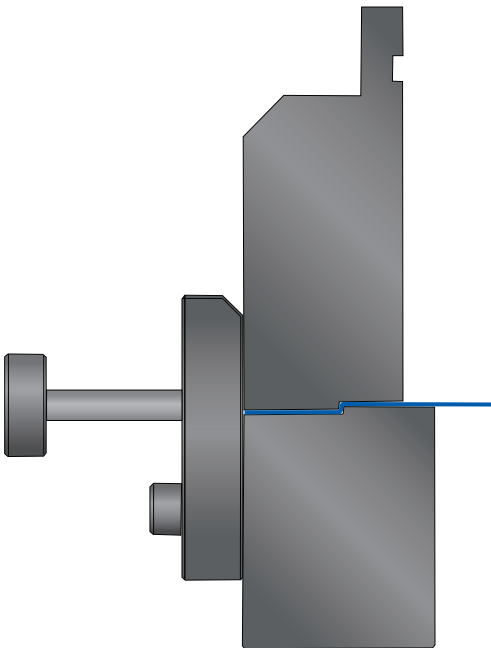

HO1 HORIZONTAL OFFSET

For offsets that are approximately one material thickness. Prevents material whip up. Thrust plates and adjustable back gauging are provided.

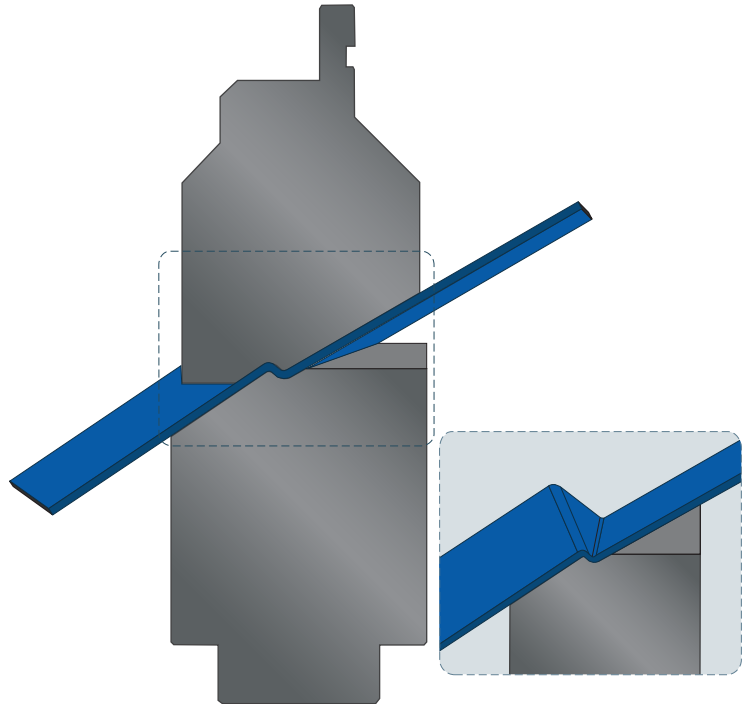

NPO1 NON PARALLEL OFFSET

For offsets that have nonparallel flanges. Inset shows punch hidden for a clear view of the formed sheet

ADJUSTABLE DIE

- Can be configured to remain on the press permanently and function as a standard die holder.
- 25.4 - 609.6 mm openings available.
- Cover bellows available to keep the grooves that are used to adjust the dies free from dirt and dust.
- Clamping options for side blocks:
 - » Manual clamping.
 - » Hydraulic clamping, manual movement.
 - » Hydraulic clamping, automated movement.

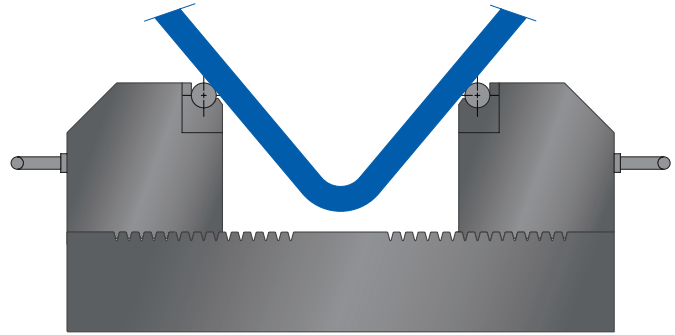

See this tool in action on the
Wilson Tool YouTube Channel

REPLACEABLE SHOULDER DIE

Replaceable shoulder dies are ideal for extreme wear conditions created then forming heavy plate and abrasive materials.

Replaceable inserts eliminate the need for replacing the entire die when the die shoulders wear.

Available in multiple V sizes and 75° and 85° configurations.

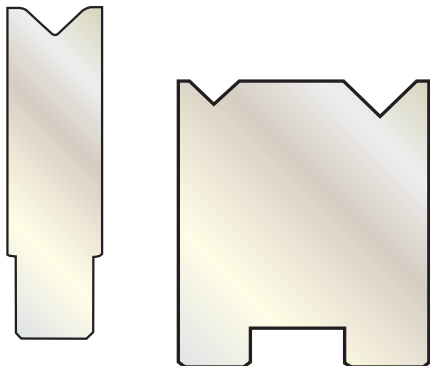
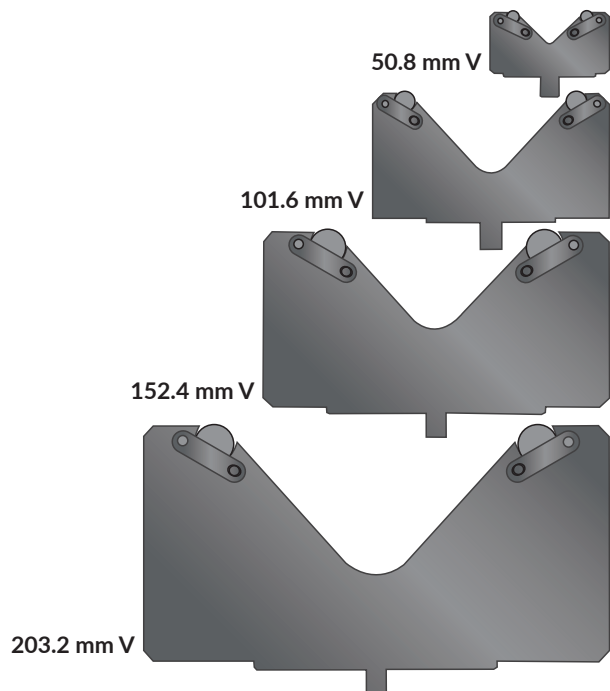

NYLON DIES

Some dies available in Nylon to reduce sheet marking. Specifically used for thinner materials including Copper, Polished Stainless and Brass.

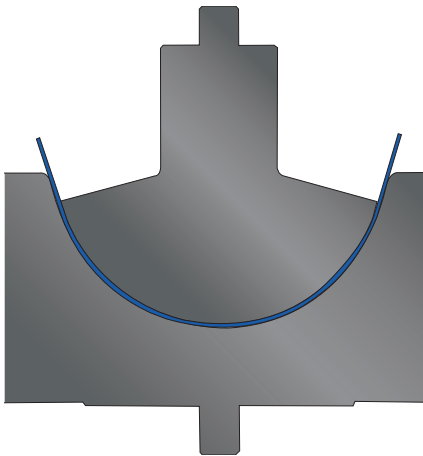

LR1 LARGE RADIUS

Bottoming radius set with spring-back allowance built in. It is manufactured to form a radius in a specific type and thickness of material for tight tolerance requirements.



See this tool in action on the [Wilson Tool YouTube Channel](#)

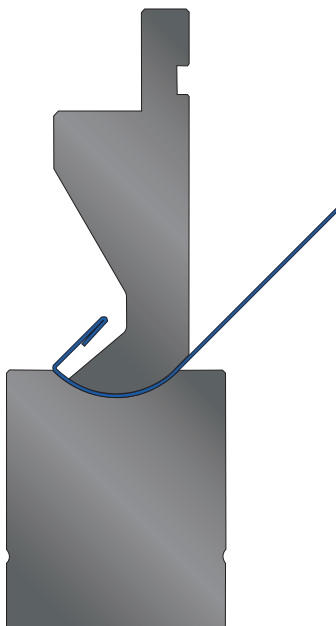

LR2 MULTI-HIT RADIUS

Used when a full radius is required before the flange. The solution may require multiple strokes.

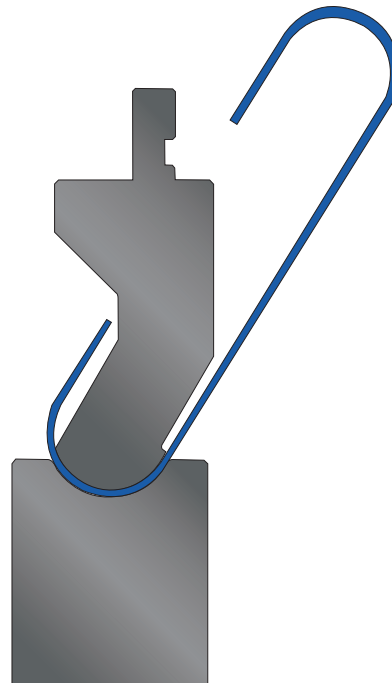

LR3 MULTI-HIT RADIUS

Used when the return flange starts at the radius end. The solution may require multiple strokes.

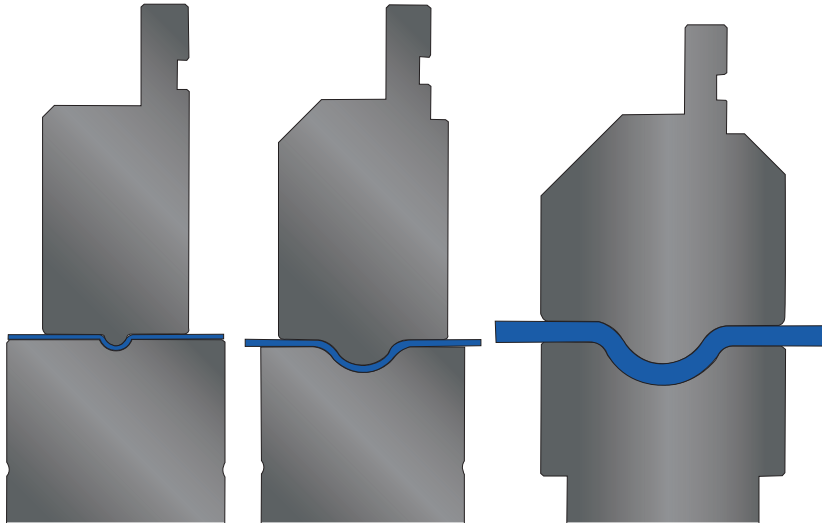
**SR1 STRENGTHENING RIB**

Produce a strengthening rib in one stroke. Spring back allowance is built in. Closed end and open end ribs are available.

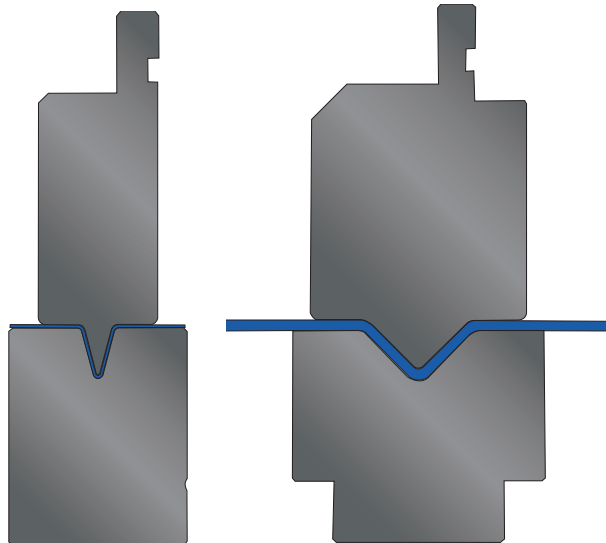

See this tool in action on the
[Wilson Tool YouTube Channel](#)

**VR1 V RIB**

Produce a V rib in one stroke. Spring back allowance is built in

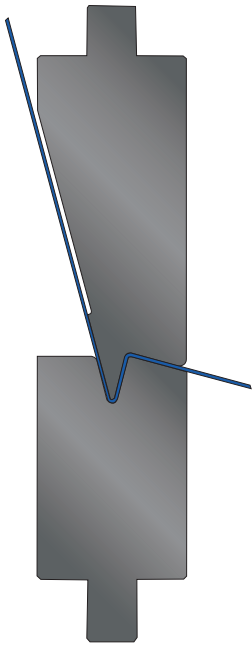

FM1 FORMING

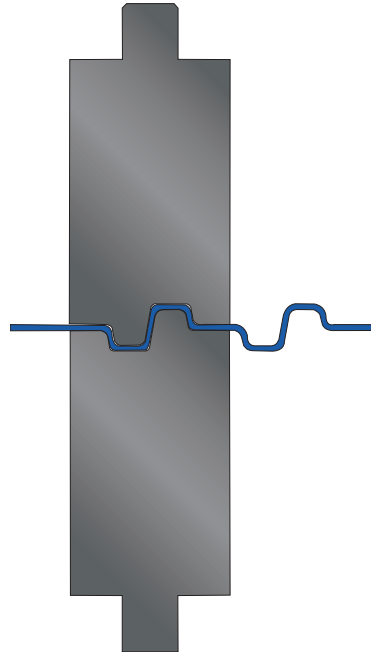

FM2 FORMING

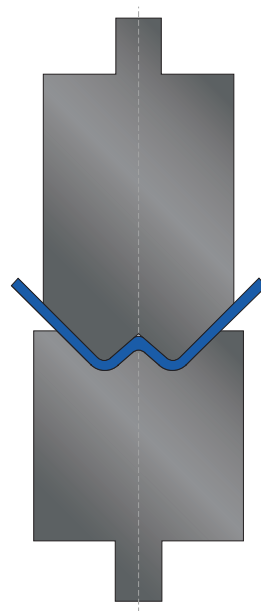

FM3 FORMING

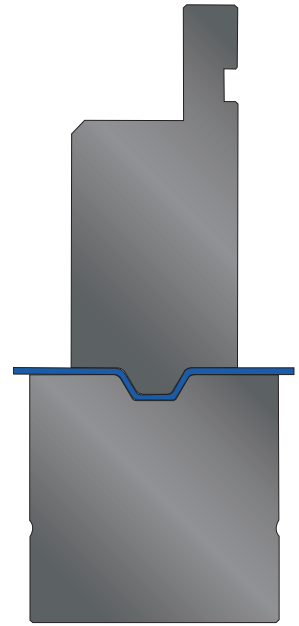

OH1 OPEN HAT

A large variety of custom forming sets are available.
 Custom built to suit any specific requirement.
 Call for specific application requirements.

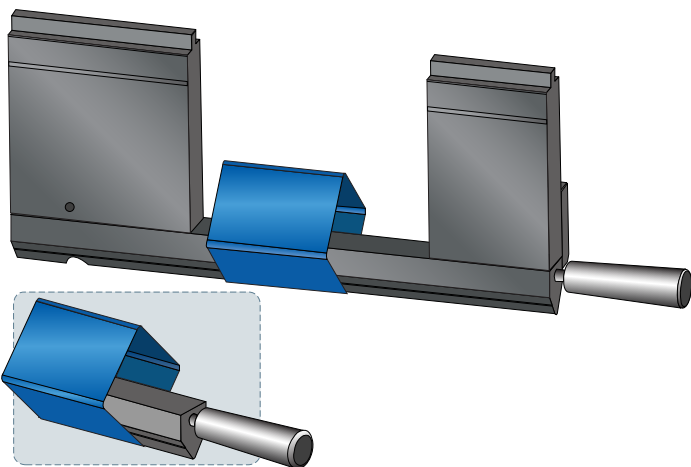

W1 WINDOW

Used when minimum return flange clearance is required.



See this tool in action on the [Wilson Tool YouTube Channel](#)

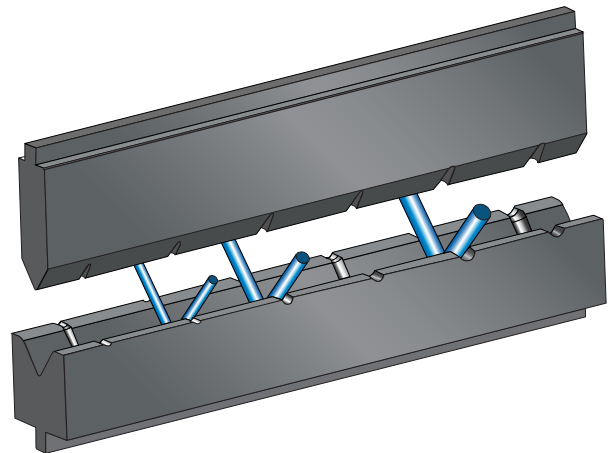

RB1 ROD BENDING

Provides nesting for the rod during the forming process.

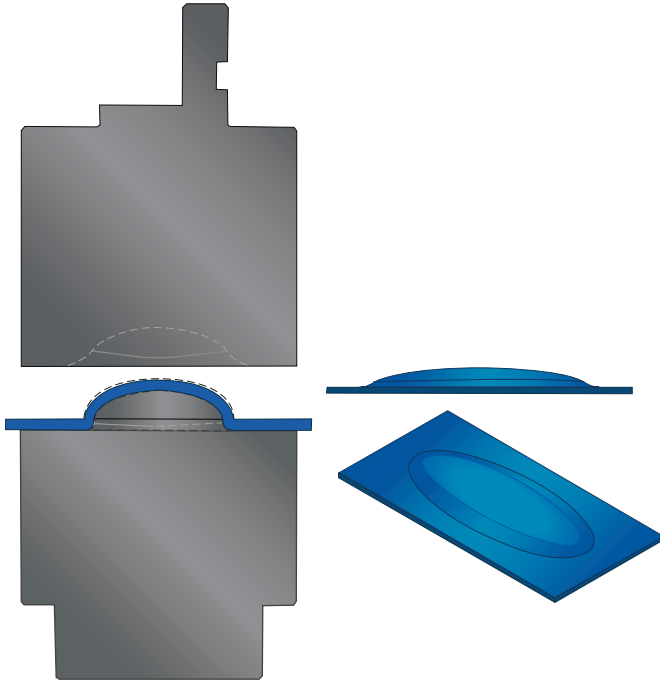

EM1 EMBOSS

A variety of raised emboss and chisel point emboss sets are available.

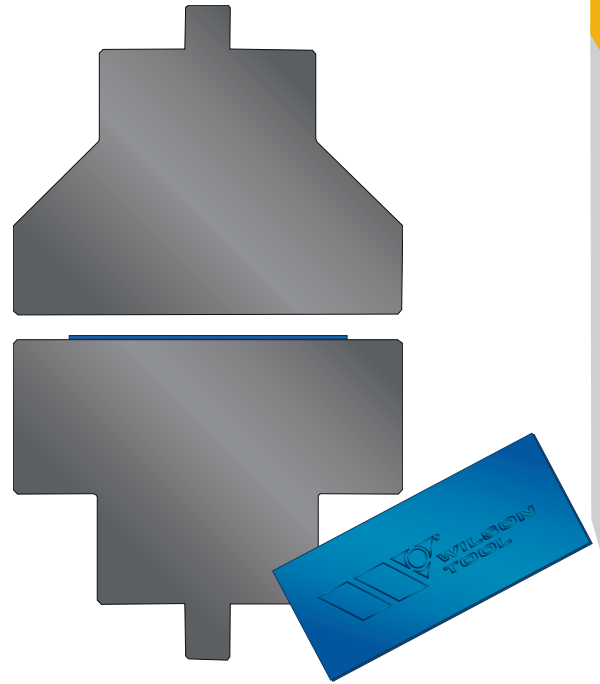

LG1 LOGO

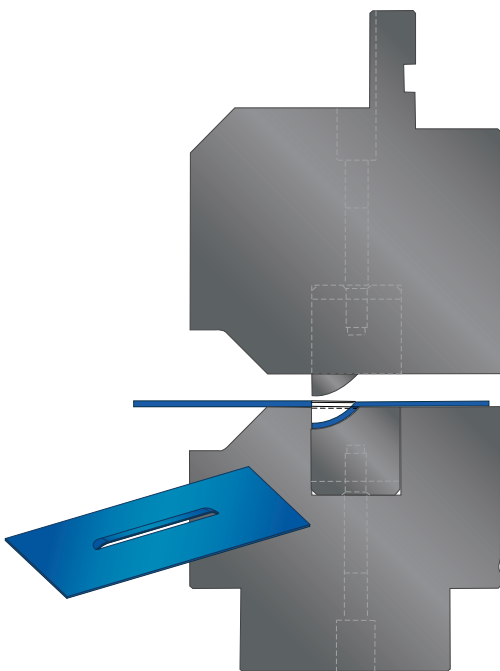

LL1 LOUVRE

Multiple louver configurations are available. For louver forming, sheet must be pre-slit.

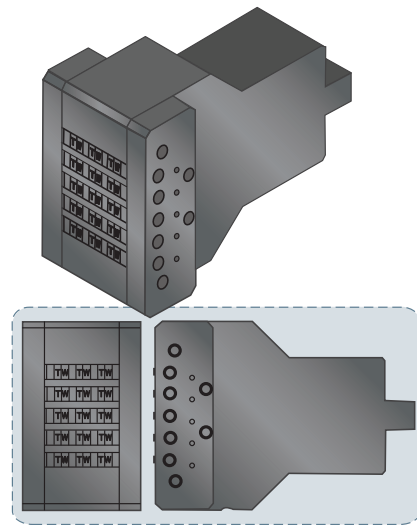

LS1 LETTERSTAMP

Provides chisel point embossing with inter-changeable characters. Single row or multi-row available.

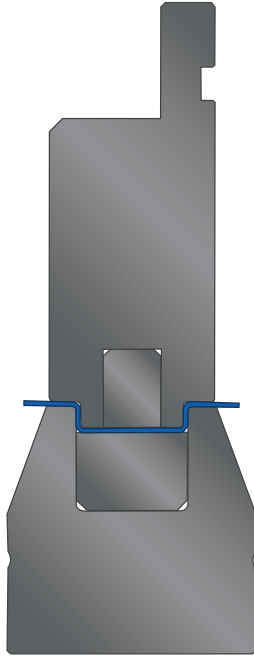

HT1 HAT CHANNEL

Provides straight wall or angled wall hat channel bending in one stroke. Spring back allowance built in.

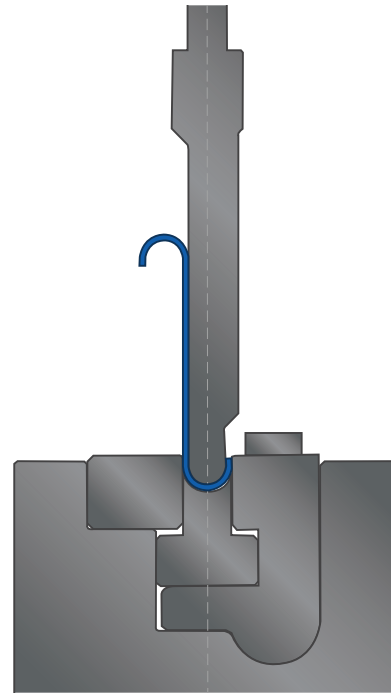

UC1 U CHANNEL

Recommended for applications where considerable spring back is encountered. Secondary flattening operations may be required.

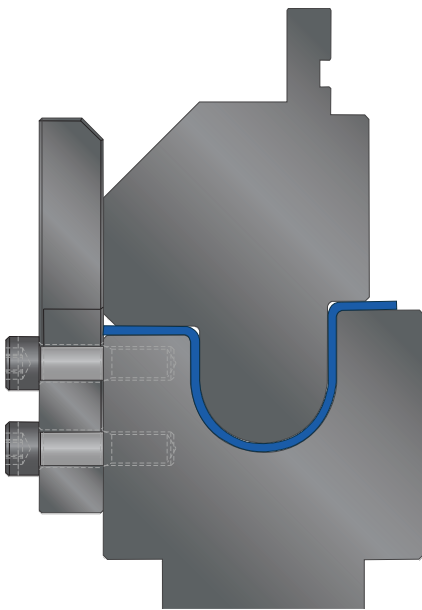

UC2 U CHANNEL

Recommended for applications where considerable spring back is encountered. Secondary flattening operations may be required.

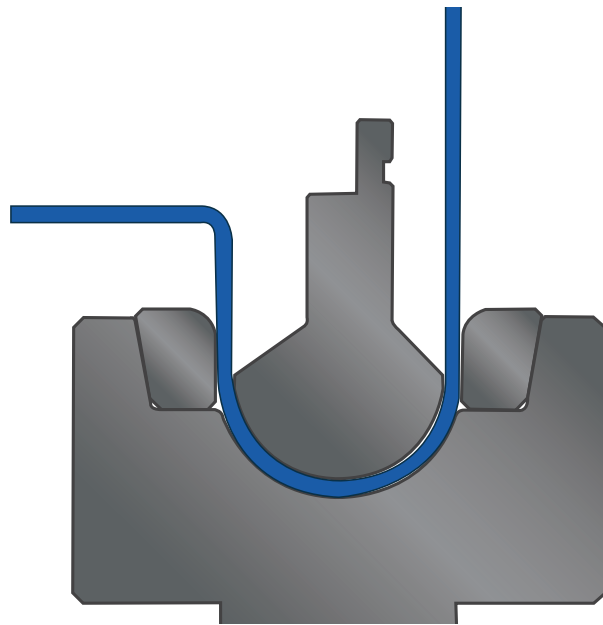

UC3 U CHANNEL

Recommended for applications where considerable spring back is encountered. Secondary flattening operations may be required.

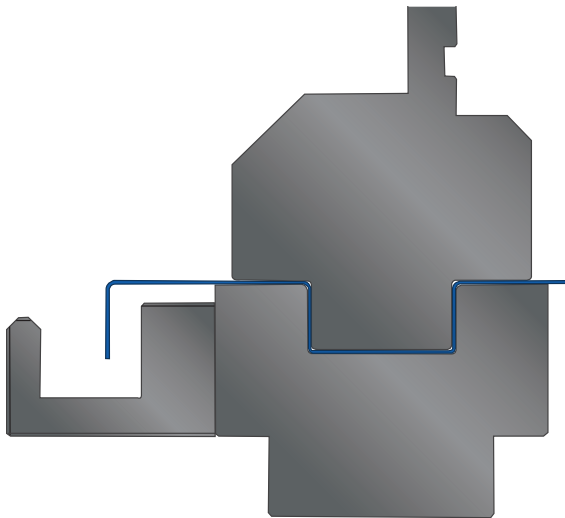

C1 CHANNEL

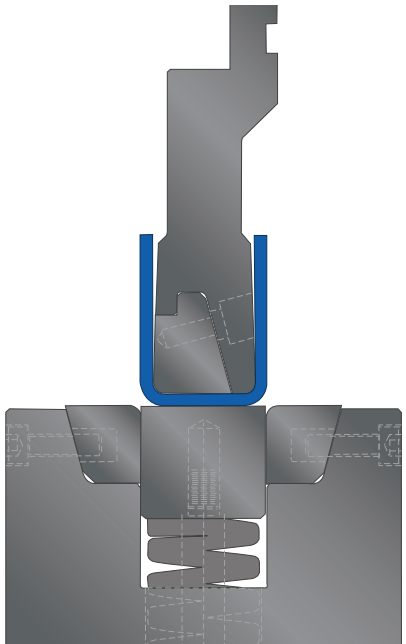

C2 CHANNEL

These applications are for deep channels when the channel bottom needs to remain flat.

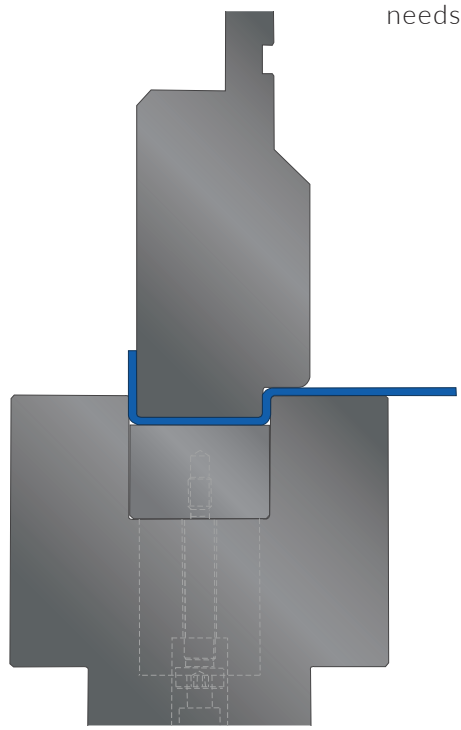

C3 CHANNEL

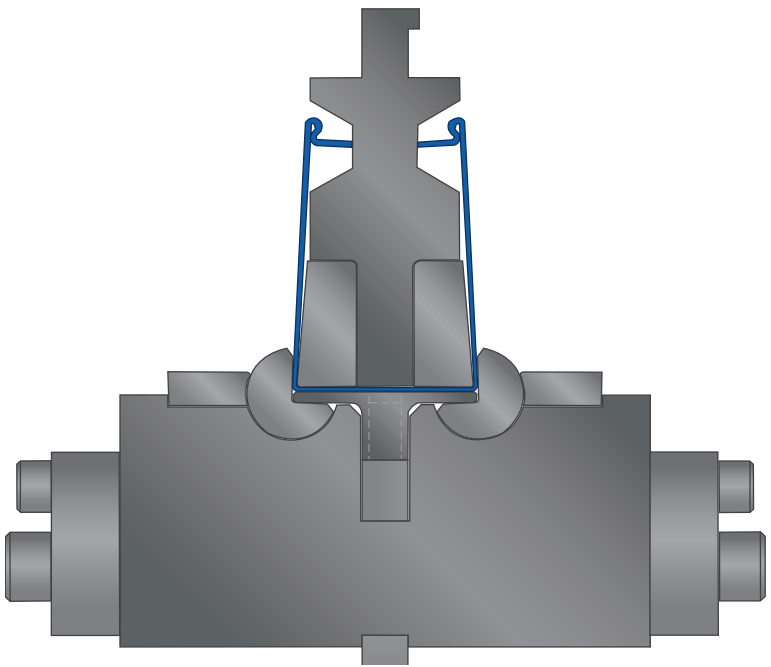

C4 ROTARY BEND CHANNEL

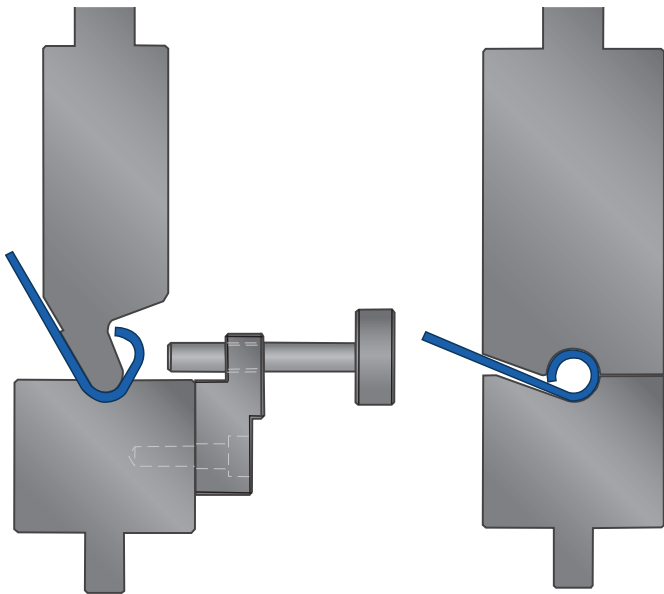

CL1 CURL TOOL SET

2 tool sets, 3 machine strokes.

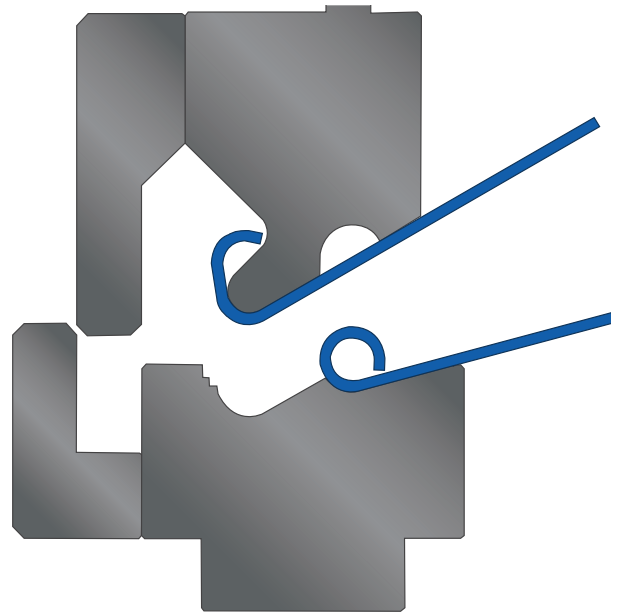

CL2 CURL TOOL SET

Typically used for thick materials and large diameter curls.
1 tool set, 3 machine strokes.

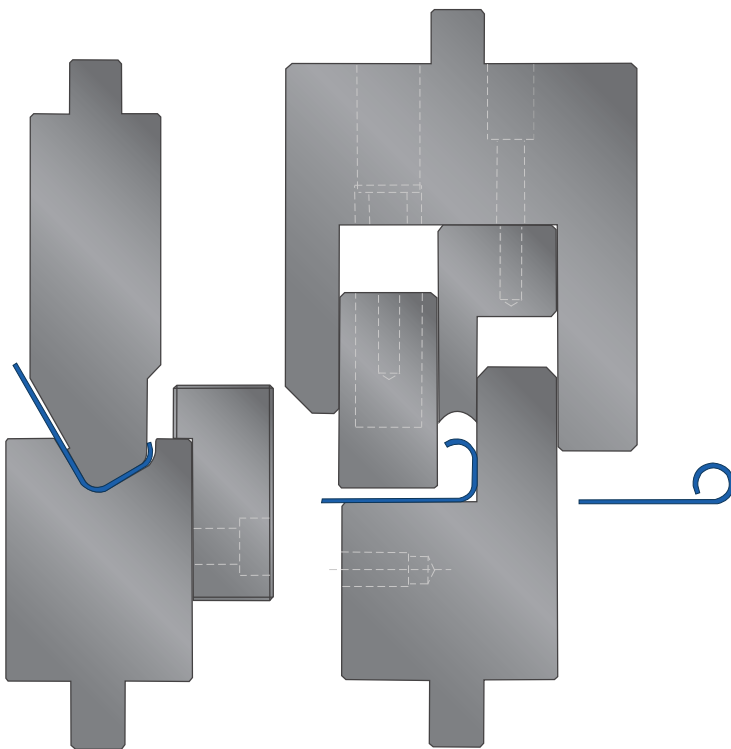

CL3 CURL

Used for hinges and corner beading. 2 tool sets, 2 machine strokes.



See this tool in action on the [Wilson Tool YouTube Channel](#)

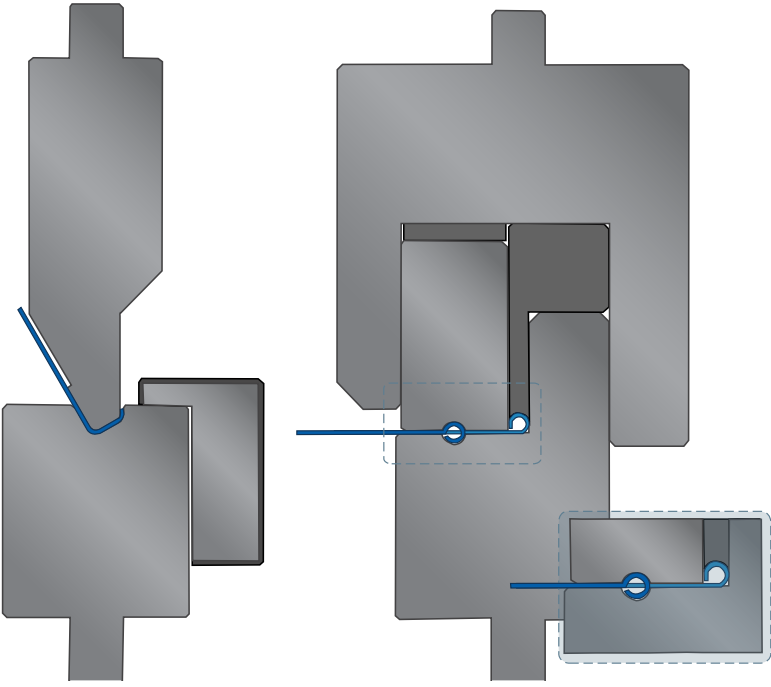

CL4 CENTER CURL APPLICATION
 2 tool sets, 3 machine strokes.

 See this tool in action on the Wilson Tool YouTube Channel

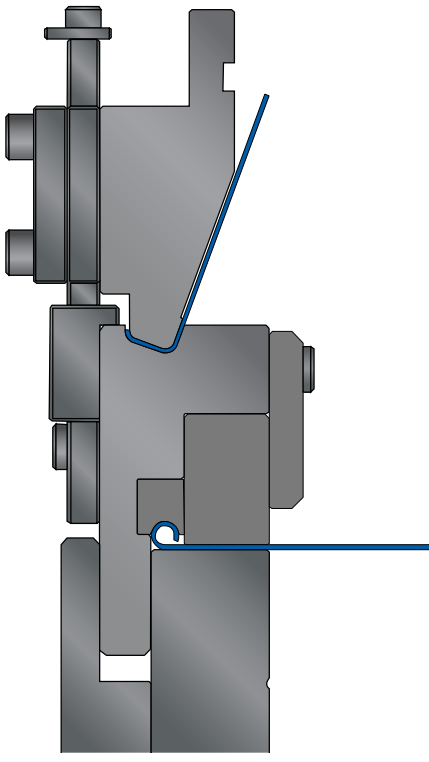

CL5 DOUBLE DECKER TOOL SET
 Used for hinges and corner beading.
 1 tool set, 2 machine strokes.

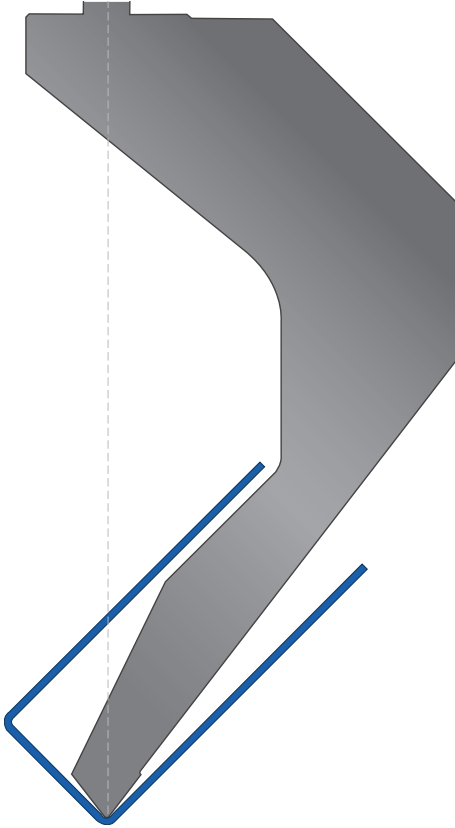

PR1

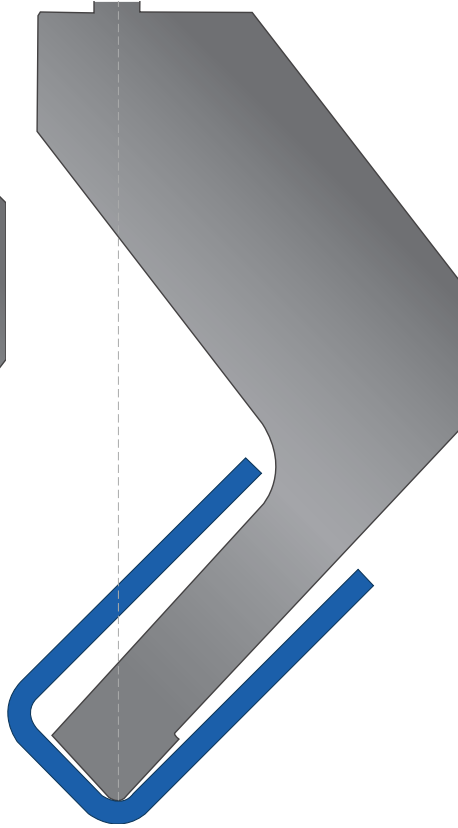

PR2

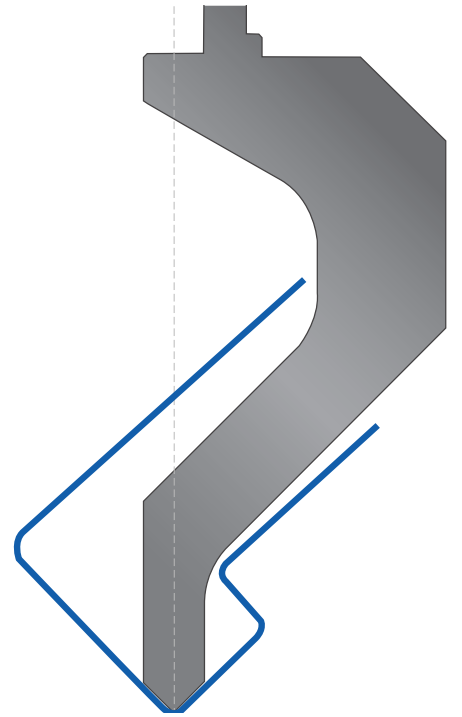

PR3

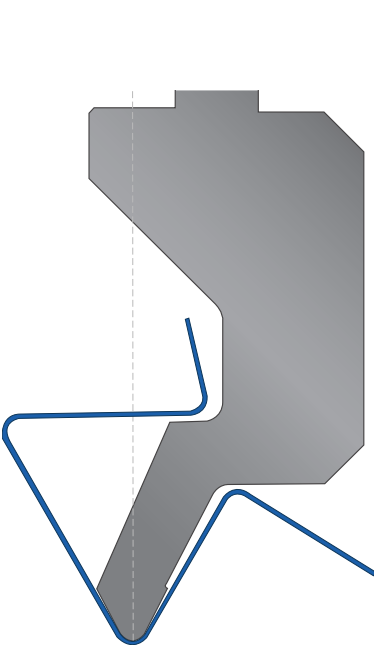

PR4

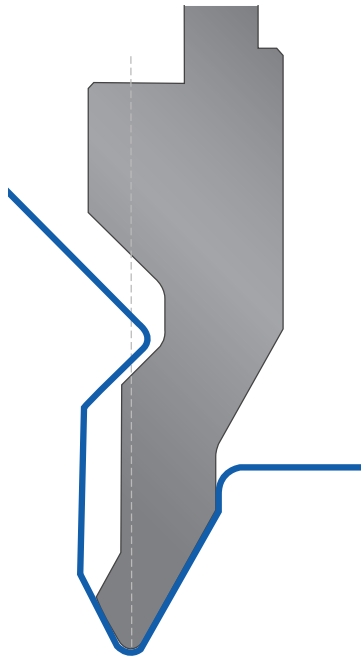

PR5

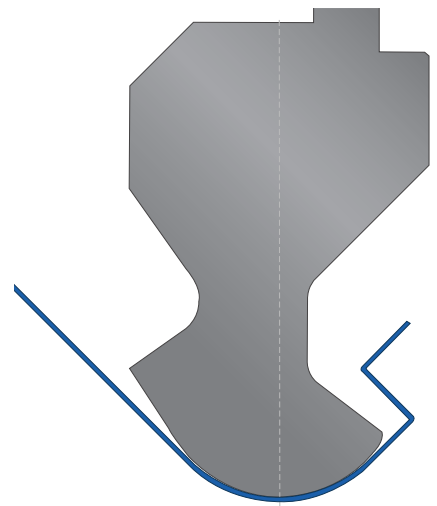

PR6

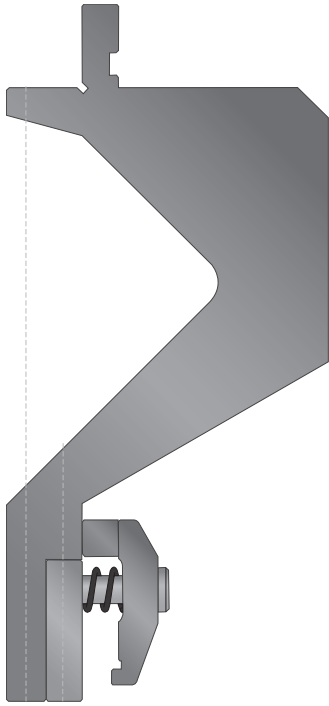

EURO Z1 OR Z2 CLAMPING
Cat No. 43002

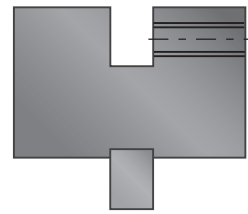

DIE HOLDER

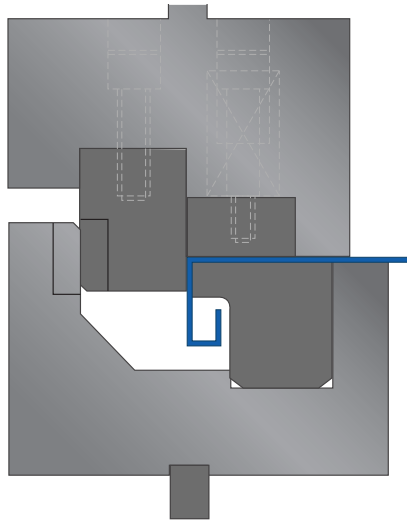

WD1 WIPE DOWN

Holds the sheet flat while wiping the flange down.
Ideal for large panels and high production.

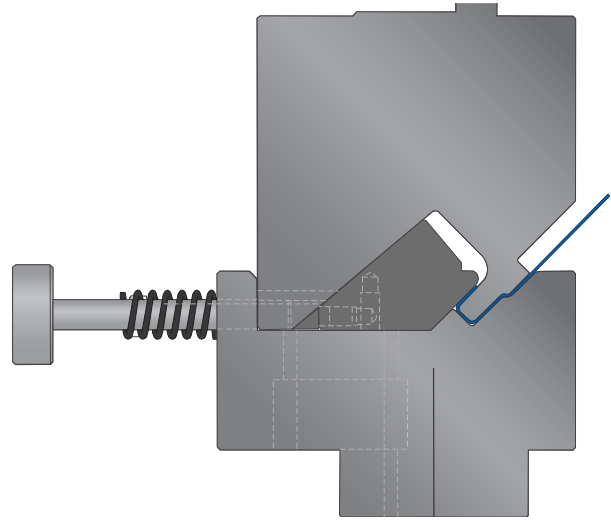

WO1 WIPING FORM

Holds the sheet flat while wiping the flange up or down.
Ideal for large panels and high production.

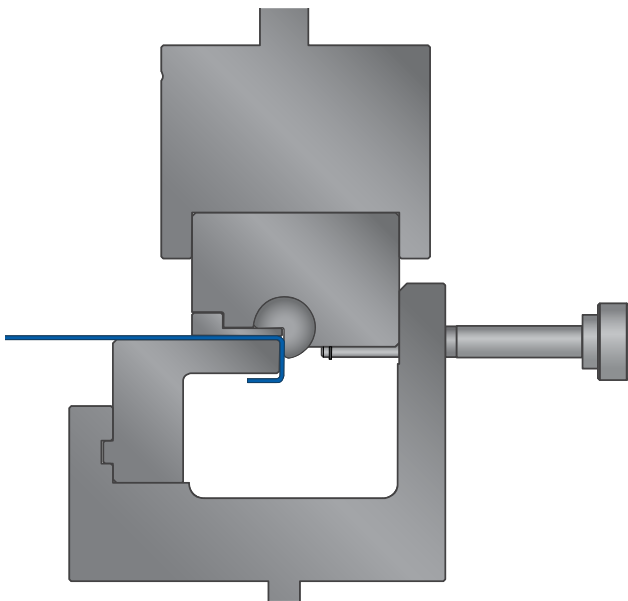

RTD ROTARY FLANGE FORMING FORM DOWN

Holds the sheet flat while forming. Overbend allowance is built in to compensate for material springback.
Ideal for large panels and high production.

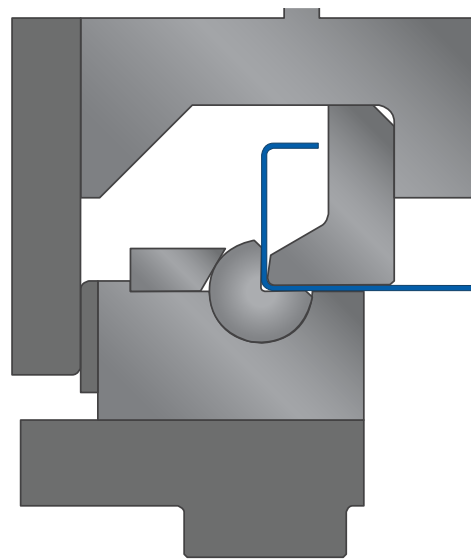

RTU

Holds the sheet flat while forming. Overbend allowance is built in to compensate for material springback.
Ideal for large panels and high production.



See this tool in action on the Wilson Tool YouTube Channel



See this tool in action on the Wilson Tool YouTube Channel

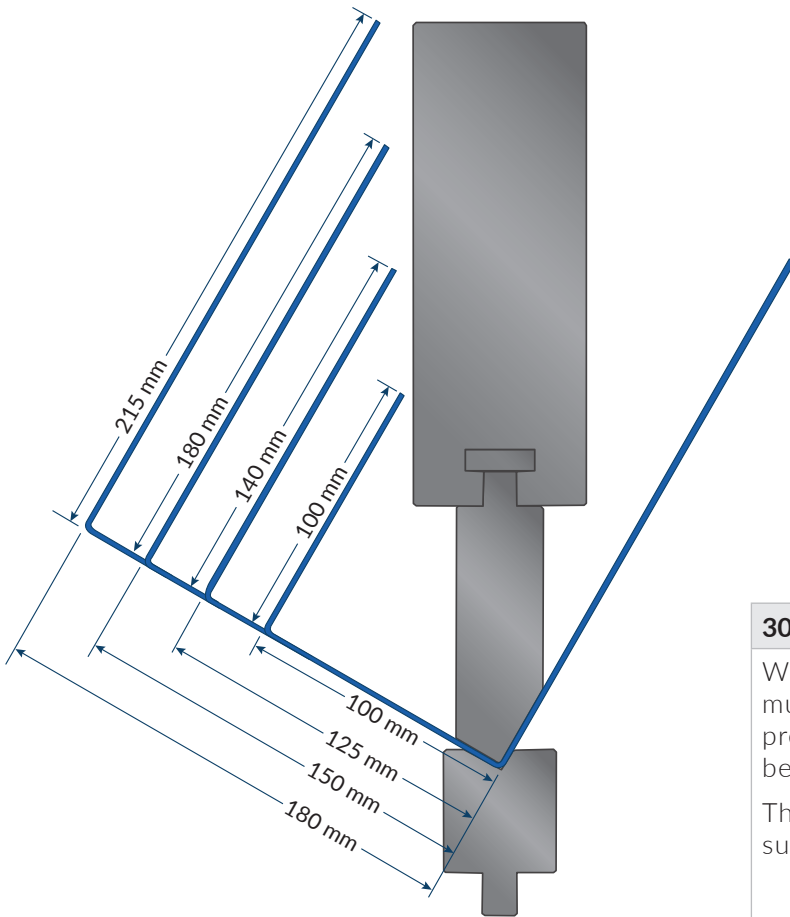

30/60 DEEP BOX BENDING

When forming a 4-sided box, the punch must be sufficient height to prevent the pre-formed side from striking the upper beam.

This is a thrusting application and not suitable for all press brakes.

SWING EAR SECTIONS

Box bending with return flanges.

Standard bend length 150mm each ear on all punch profiles, 100mm length available on select profiles.

Ear(s) recess/fall in left to right 13mm - 19mm, not to be confused with vertical movement. There will be approximately 25mm - 38mm of relief to rotate and drop the finished part.

Punch profile will match the standard profile only in height, angle and radius. Width will be wider where hinged.

Consider open height and stroke with the additional height achieved by ear movement.

Application driven - consult with sales desk to review expected results prior to ordering.

Priced per pair (total 305mm length), singles priced upon request.

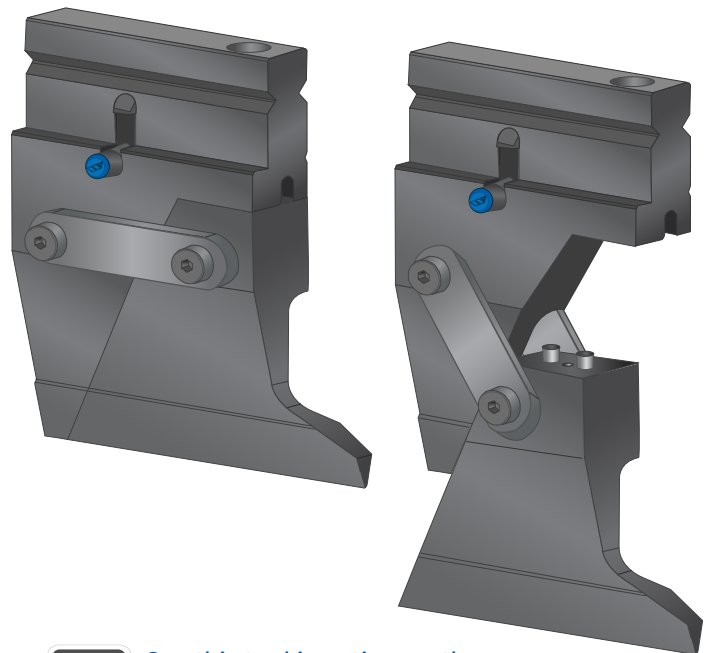

See this tool in action on the [Wilson Tool YouTube Channel](#)

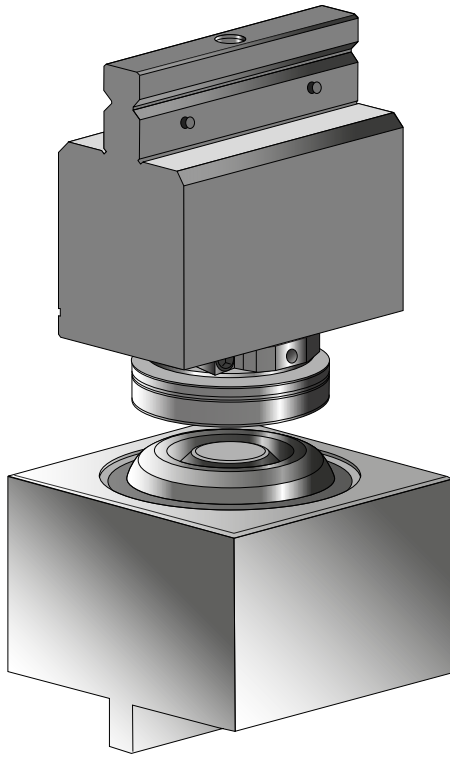
**TA1 TURRET ADAPTER**

This tooling set adapts punch press tooling to use in a press brake.

Multiple configurations and options are available.

Note: For Forming applications only.



The Wilson Xtra range includes machines, storage solutions and accessories for the sheet metal industry. Wilson Xtra storage solutions can be configured to suit your 5S storage needs, with a range of different sized cabinets and inserts to suit press brake tooling, punch press tooling and other accessories. The range also includes accessories for punch press and brake press machines, as well as hand tools for sheet metal workshops.

ULTRASONIC CLEANER

Material build-up, or “Galling”, will have a detrimental impact both on the life of your tooling and on the quality of the parts produced on your punch press.

To protect the investment you have made in punch press and press brake tooling, Wilson Tool can now offer a range of high quality and innovative Ultrasonic cleaners that will remove galling in minutes without damaging the tool surface.



Press Brake Compatible

Punch Press Compatible

ITEM	VOLUME	BASKET SIZE	CAT. NO.
M3	1.9 Litres	198 mm x 106 mm x 50 mm	55323
M12	9 Litres	250 mm x 190 mm x 115 mm	55324
M30	20.6 Litres	455 mm x 250 mm x 115 mm	55325
M80i	80 Litres	540 mm x 290 mm x 340 mm	55328
M120i	120 Litres	540 mm x 400 mm x 390 mm	55329
M160i	160 Litres	1120 mm x 290 mm x 340 mm	55330
Cavitec HD Pro	25 Litres	Detergent solution, 10-40% ratio in water	55348



See this tool in action on the Wilson Tool YouTube Channel

LARGE XTREME STORAGE CABINET

TYPE	DIMENSIONS (W X H X D)	CAT. NO.
XSC 531	1040 x 2140 x 1050 mm	55165
XSC 532	1040 x 2140 x 1300 mm	55129



Press Brake Compatible

 Punch Press Compatible

MEDIUM XTREME STORAGE CABINET

TYPE	DIMENSIONS (W X H X D)	CAT. NO.
XSC 521	1040 x 1620 x 1050 mm	55357
XSC 522	1040 x 1620 x 1300 mm	55358



Press Brake Compatible

 Punch Press Compatible

SMALL XTREME STORAGE CABINET

TYPE	DIMENSIONS (W X H X D)	CAT. NO.
XSC 311	660 x 1240 x 1050 mm	55125
XSC 312	660 x 1240 x 1300 mm	55292
XSC 511	1040 x 1240 x 1050 mm	55164
XSC 512	1040 x 1240 x 1300 mm	55128



Press Brake Compatible

 Punch Press Compatible

*For more information on cabinets and drawer inserts refer to the Wilson Tool X-tra Catalogue

Press Brake Compatible
.....
Punch Press Compatible

DESCRIPTION	CAT. NO.
0.4mm x 152mm x 30m	42530
0.8mm x 152mm x 30m	42531
High Density (colour blue) 0.6mm x 152mm x 30m	42532



URETHANE ROLLS

Urethane drapes provide a protective layer across the top of your standard dies to virtually eliminate sheet marking. Our high density urethane offering is 0.6mm thick, lasting significantly longer than standard urethane.

Press Brake Compatible
.....
Punch Press Compatible

DESCRIPTION	CAT. NO.
12.5 m length x 120 mm width	55335
Retention Magnets (10)	55291
Fabric Roll w = 240mm	55337



PROTECTIVE FABRIC DRAPE

A long-life coated 0.2mm fabric to protect your products from die impressions during the bending process. Forms a protective layer between sheet and die without causing any angular deviation.

Press Brake Compatible
.....
Punch Press Compatible

DESCRIPTION	CAT. NO.
100 mm x 5 m	55317
100 mm x 10 m	55318



KIZU-BENDING FABRIC

A knitted elastic textures material, which helps to reduce bending stress and die wear.

SIDE GAUGE

Press Brake Compatible

 Punch Press Compatible



Intended for use with Quick Change, 2V, Sectionalized 2V and Quick Change 1V dies.

SQUARING ARM

Press Brake Compatible

 Punch Press Compatible



The Wilson Squaring Arm is a flexible tool enabling you to get more parts through your Press Brake with high accuracy.

1V & 2V STABILIZER

Press Brake Compatible

 Punch Press Compatible

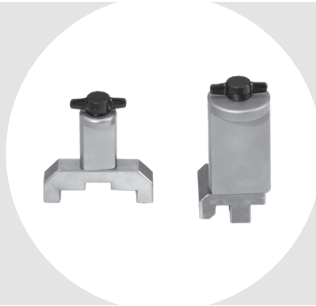

Fits to guide rail to support short sections of Quick Change 1V and 2V dies.

1V 2V

Cat. No. 42704 Cat. No. 42705

EXPRESS CLAMP TORQUE WRENCH

Press Brake Compatible

 Punch Press Compatible



CAT. NO.	DESCRIPTION
8002	Complete Kit
8003	Case
43726	Pivots
6793	Wrench
6795	Hex Tips

- Compact size with spring loaded jaw mechanism
 - Accuracy to 0.051 mm
 - Readings in millimeters, inches and fractions
-



DIGITAL THICKNESS GAUGE

Press Brake Compatible
.....
Punch Press Compatible

- Large digital readout 22.23 x 60.33 mm
 - Measuring range 0 - 152.4 mm
 - Accuracy to 0.025 mm
-



DIGITAL EASY READ CALIPER

Press Brake Compatible
.....
Punch Press Compatible

- Real time display of angle comparison
 - Magnets on three sides
 - Self rotating display for 180° readings
-



DIGITAL ANGLE CUBE

Press Brake Compatible
.....
Punch Press Compatible

Lightweight, easy-to-use, highly accurate protractors measure angles from 0 - 360° with digital precision.

.....



DIGITAL PROTRACTORS

Press Brake Compatible
.....
Punch Press Compatible

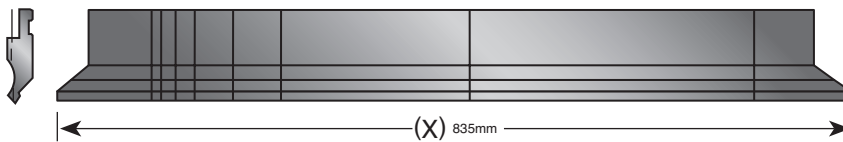
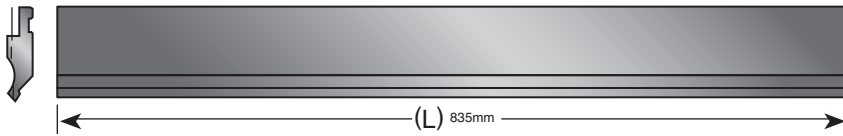
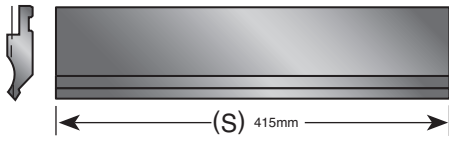

PUNCH FEATURES:

1. Most tools can be easily loaded by a single operator.
2. Easy to store.
3. All sectionalised tools come pre-cut in nine different pieces.
4. Most sectionalised punches include two ear pieces (horns).
5. Punches are induction hardened, to 59-60 HRC but NITREX™ (HRC - 60) is available for every punch in the tooling line.
6. Special Tooling available. Please contact the sales desk.

PUNCH SECTION WIDTHS:

100mm **LEFT EAR** / 100mm **RIGHT EAR** / 10mm / 15mm / 20mm / 40mm / 50mm / 200mm / 300mm

Note: Special lengths are available at additional cost, just select the standard length and ask us to cut to your requirements.

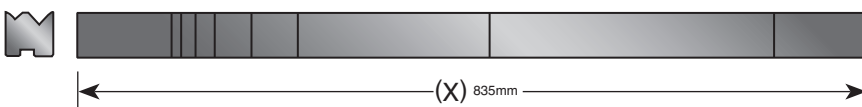
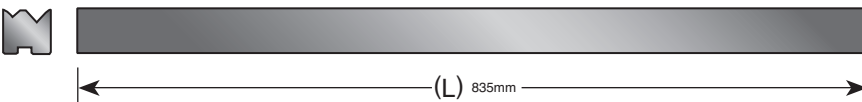
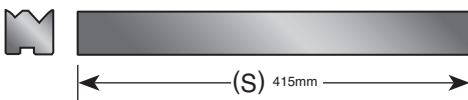

DIE FEATURES:

1. Most tools can be easily loaded by a single operator.
2. Easy to store.
3. All sectionalised tools come pre-cut in nine different pieces.
4. Most dies are NITREX™ enhanced (HRC 60) as standard. Others are induction hardened.
5. Special Tooling available. Please contact the sales desk.

DIE SECTION WIDTHS:

100mm / 100mm / 10mm / 15mm / 20mm / 40mm / 50mm / 200mm / 300mm

Note: Special lengths are available at additional cost, just select the standard length and ask us to cut to your requirements.

STANDARD FORMULAS FOR SELECTING A V-OPENING MATERIAL THICKNESS

26mm OR LESS	=	T x 6	Note:
30mm-8.0mm	=	T x 8	The formulas are for reference only. For more specific information, please refer to the chart below. Chart below is for mild steel.
9.0mm-12.0mm	=	T x 10	
14.0mm and THICKER	=	T x 12	

TONNAGE REQUIRED FOR MILD STEEL

Soft Brass	x	0.5
Soft Aluminium	x	0.5
Heat Treated Aluminium Alloys	x	1
Stainless Steel	x	1.5

FIGURES BASED ON MILD STEEL

THICKNESS	V (mm)																						
	4	6	7	8	10	12	14	16	18	20	22	25	32	40	50	63	80	100	125	160	200	250	
0.5mm	MF	2.8	4.2	4.9	5.6	7.0	8.6	10.1	11.5	13.0	14.4	*15.8	18.0	24.0	30.0	37.5	47.3	60.0	75.0	96.3	123.2	154.0	192.5
	IR	0.7	1.0	1.2	1.3	1.7	2.0	2.3	2.7	3.0	3.3	3.7	4.2	5.3	6.7	8.3	10.5	13.3	16.7	20.8	26.7	33.3	41.7
0.6mm		6.0	4.2	3.3	3.2																		
0.8mm			8.0	7.2	5.6	4.4																	
1.0mm				11.0	10.0	9.0	7.0	5.5															
1.2mm					14.0	13.2	10.8	8.4	7.5	6.6													
1.4mm						15.4	14.0	12.6	9.8	8.8	7.7												
1.6mm							17.6	16.0	14.4	11.2	10.0	8.8											
2.0mm	T							22.0	20.0	18.0	16.0	14.0	12.5	11.0									
2.3mm	O								25.3	23.0	20.7	18.4	16.1	14.4	12.7								
2.6mm	N									28.6	26.0	23.4	20.8	18.2	14.3								
3.0mm	S										33.0	30.0	28.53	27.0	21.0	16.5							
3.2mm												35.2	31.9	28.8	22.4	17.6	14.4						
3.5mm	P												38.5	35.0	28.0	21.9	15.8	14.0					
4.0mm	E													44.0	36.0	28.0	22.0	18.0					
4.5mm	R														45.0	36.0	28.1	20.3					
5.0mm															55.0	36.0	28.1	20.3					
6.0mm	M															45.0	35.0	26.3	22.5				
7.0mm	E															60.0	54.0	37.5	31.5	24.0			
9.0mm	T																56.0	43.8	31.5	28.0			
10.0mm	R																	72.0	56.3	40.5			
12.0mm	E																	90.0	70.0	52.5	45.0		
16.0mm																			108.0	84.0	63.0	54.0	
19.0mm																				144.0	112.0	84.0	72.0
22.0mm																					152.0	118.8	99.8
25.0mm																						176.0	137.5
30.0mm																						225.0	175.0
																							270.0

- T = MATERIAL THICKNESS
- V = V-OPENING
- MF = MINIMUM FLANGE LENGTH
- IR = INSIDE RADIUS

The bending force (tonnage) figures listed above are based on mild steel with a tensile strength of 45-50 kilograms per square millimetre. To calculate the approximate bending force (tonnage) requirements for other materials, please use the multipliers listed.

Note: * Based on bending to an included angle of 88 degrees. This dimension will increase when bending to an included angle of less than 88 degrees.

Order	Minimum order is
Credit	All orders are subject to the approval of our credit department. If you are a new account, please furnish us with a bank reference and three supplier references. A credit limit will be imposed on new accounts until credit has been established.
Payment	Terms are net 30 days.
Cancellation	In the event an order is cancelled, a charge will be made to cover labour, materials and overheads.
Returned Material	A handling charge of 25% is made on all standard parts returned for credit. Written permission and shipping instructions must be obtained before the return of any material. Special tooling cannot be returned.
Claims	All claims for shortages must be made within 3 days of the invoice date.
Prices	Prices and specifications subject to change without prior notice. E & OE. All prices are exclusive of VAT.

WILSON TOOL INTERNATIONAL (EUROPE) LTD.

WORLD HEADQUARTERS

Wilson Tool International - United States

Tel (Free): 800-328-9646 | Tel: 651-286-6001
Email: sales@wilsontool.com

NORTH AMERICA

Wilson Tool - Canada

Punching and Stamping Division
Email: punching@wilsontoolcanada.com

Wilson Tool - Canada

Press Brake Division
Tel: 800-268-4180
Email: bending@wilsontoolcanada.com

Wilson Tool - Mexico

Tel: (81) 1665 1249
Email: americalatina@wilsontool.com

SOUTH AMERICA

Wilson Tool - Argentina

Tel: +54 114 799 6519
Email: ventassudamerica@wilsontool.com

Milling Ferramentas - Brazil

Tel: 55 11 5621-2100
Email: vendas@milling.com.br

EUROPE / MIDDLE EAST / AFRICA

Wilson Tool - United Kingdom

Tel (Free): 0800-373748 | Tel: +44 1793 831818
Ireland Tel (Free): 1-800 709 009
Email: pb.sales@wilsontool.eu.com

Wilson Tool - Germany

Tel: +49 5723 747 0
Fax: +49 5723 747 10
Email: verkauf@wilsontool.eu.com

Wilson Tool - Denmark

Tel: +45 44 53 1699 | Fax: +45 44 53 0607
Email: salesdk@wilsontool.eu.com

Wilson Tool - France

Tel: +33 (0) 164 13 47 80 | Fax: +33 (0) 164 13 47 81
Email: ventes@wilsontool.eu.com

Toolspress - Italy

Tel: +39 0521 850510 / 850677
Fax: +39 0521 850796
Email: sales@toolspress.com